

# COVERT

## VEHICLE RECOVERY WINCH



# COVERT

## VEHICLE RECOVERY WINCH

Congratulations on the purchase of your Bushranger vehicle recovery winch. Be proud that this product has been designed and thoroughly tested in Australia to meet the specified applications (see limitations in 'Warnings & Safety') and with proper care and preventative maintenance, will give you years of trouble-free operation. All information in this publication is based on the latest production information available at the time of print. We reserve the right to make changes without notice because of continued product improvement.

Your Bushranger winch has been designed to give safe and dependable service if operated according to the instructions. Please read and understand this manual before installation and operation of the winch. Careless winch operation can result in serious injury or property damage.

When requesting information or ordering replacement parts, always give the following information:

1. Winch model and voltage
2. Serial Number
3. Item. No. and Part Number
4. Part Description

# TABLE OF CONTENTS

Warnings & Safety .....	1
Specifications .....	3
Installation .....	5
Operational Checklist (Prior to use) .....	9
Winch Products/Accessories .....	10
Winching Principles .....	11
Winch Operation .....	14
Maintenance .....	20
Troubleshooting .....	23
Winch Assembly & Parts List .....	24
Warranty .....	30



## CAUTION

### READ USER MANUAL BEFORE OPERATION OR INSTALLATION.

Do not operate or install without understanding these instructions and having a working knowledge of winching techniques.



## Warnings

1. It is highly recommended that prior to using this vehicle recovery winch, that users undertake off road training including vehicle recovery. Recovering immobilised vehicles is a potentially dangerous exercise and this winch is to be used with great care.
2. The winch is rated at the first layer of rope on the drum for intermittent periodic duty.
3. The winch is not to be used to lift, support or otherwise transport personnel.
4. A minimum of five (5) wraps of steel wire rope and ten (10) wraps of synthetic rope around the drum is necessary to support the rated load.
5. Keep clear of winch, rope, hook, and fairlead while operating.
6. Rope can break without warning. Always keep a safe distance from the winch and rope while under a load.
7. Failure to adequately align, support, or attach the winch to a suitable mounting base could result in a loss of efficiency of performance or damage to the winch, rope and mounting platform.
8. The winch can generate a huge amount of tension and force. Be aware of moving parts and keep hands clear of the winch drum, as well as where the rope feeds through the fairlead.
9. A fully charged battery and good electrical connections are essential for correct operation of your winch. A 12V 650CCA (cold cranking amps) battery is the minimum recommendation.



## Safety

- Before use, ensure that you are familiar with all winching operations (winch speeds & direction).
- In some cases, the operator of a winch may be required to have Qualifications according to applicable laws and ordinances.
- Check all safety and environmental conditions prior to and during use.
- Only use correctly rated rope. Inspect for damage and/or defects before use.
- Do not use an unsuitable hook or snatch block for rope.
- The operator must remain with the winch during operation.
- The winch duty rating is S3 (intermittent-periodic). See page 13.
- Do not use the winch as a lifting device or a hoist for vertical lifting and moving people.
- Ensure that the winch is connected to the correct voltage (12VDC only).

- Do not exceed the maximum line pull ratings shown in this manual. Shock loads must not exceed these ratings.
- Pull from an angle below 15° in the horizontal plane to straighten up the vehicle or load.
- Always use appropriate gloves when handling the winch rope.
- When winching, always use a recovery damper. Place over the rope in the middle third of its length.
- A rope should be replaced if it shows signs of excessive wear, broken strands, corrosion for wire rope and excessive abrasion or fused and melted fibre for synthetic rope or any other defects.
- If the winch fails to pull a load under normal conditions, manually stop the operation, otherwise motor damage may occur.
- Check that the clutch handle is in the "Engaged" position during and after use.
- Disconnect the wired remote control from the winch when not in use and store in a safe, dry place.
- Do not wrap the rope around the load and back onto itself. Always use a tree trunk or winch extension strap.
- Keep hands and clothing clear of the winch, rope, and fairlead opening.
- Never unplug the remote control when winching a load.
- To avoid insufficient power when winching a load, the vehicle should be running and in neutral.
- Keep the remote control clear of the rope at all times.
- If noise or vibration occurs when operating, stop the winch immediately. If there are any technical concerns speak to your place of purchase or authorized dealer.
- The rope must be wound in an under-wound orientation only to ensure correct brake operation.
- Always inspect the hook, latch and pin prior to use. Do not use if there are any signs of excess distortion or bending.
- Ensure the pin of the hook is secured using a correctly installed split/cotter pin.

**WRONG FITMENT**

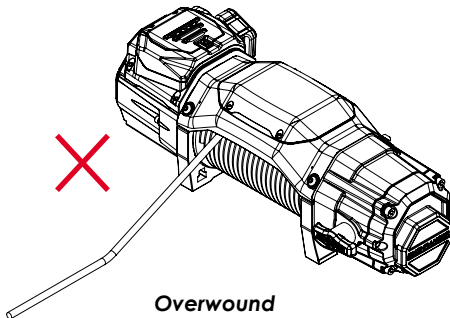

**CORRECT FITMENT**

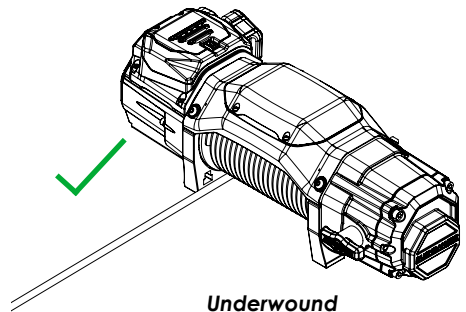

# Bushranger COVERT 10 Specifications

## Specifications:

<b>MODEL</b>	RWC100S   RWC100W	
<b>DIMENSIONS</b>	583mm(L) x 171mm (W) x 202mm (H)	
<b>WEIGHT (FITTED)</b>	31.5kg   43kg	
<b>RATED LINE PULL (1ST LAYER)</b>	10,000lbs (4,536kg)	
<b>MOTOR</b>	4.0kW (5.3 HP)	
<b>REMOTE CONTROL</b>	Dual Connection Remote Wireless - 30m range / Wired - 5m Lead	
<b>ELECTRICAL CONTACTOR</b>	Bespoke Albright DC Contactor - 500Amp	
<b>GEARBOX</b>	2 Stage Planetary & 2 Stage Spur gear	
<b>BRAKE</b>	Gearbox mounted 100% load holding proportional friction brake	
<b>CLUTCH</b>	Rotating Ring Gear - Lift & Turn Handle	
<b>ROPE</b>	Black 10mm diameter x 28m Synthetic Rope with Protective Sleeve	9.2mm Diameter x 28m Wire Rope
<b>FAIRLEAD</b>	Two Position, Aircraft Grade Aluminium Hawse fairlead	Stainless Steel 304 Roller Fairlead
<b>FINISH</b>	Electrophorus Pre Treated Black Satin Powder Coated Finish	
<b>WATERPROOF RATINGS</b>	IP68 Winch Motor and Gearbox	
<b>WARRANTY</b>	Limited Lifetime Warranty (7 Year Warranty on Electrical Components)	
<b>CERTIFICATIONS</b>	CE	

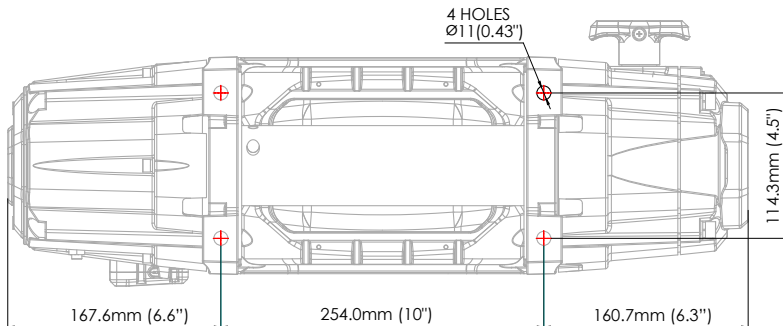

## Performance - 1st layer of drum

LINE PULL		COVERT LINE SPEED		MOTOR CURRENT
lbs	kgs	ft/min	m/min	Amps
0	0	60.6	18.5	60
4000	1816	10.6	3.2	211
6000	2724	7.6	2.3	277
8000	3632	5.9	1.8	336
10,000	4540	3.9	1.2	393

## Performance - Pull by layer

SYNTHETIC				
Layer	kgs	lbs	Total rope on drum (m)	Total rope on drum (ft)
1	4536	10,000	5.1	16.7
2	3561	7849	11.4	37.4
3	2930	6460	18.6	61
4	2490	5489	26.7	87.6
5	2164	4771	28	92

WIRE				
Layer	kgs	lbs	Total rope on drum (m)	Total rope on drum (ft)
1	4536	10,000	5.5	18
2	3561	7849	12.2	40
3	2930	6460	19.8	65
4	2490	5489	28	92

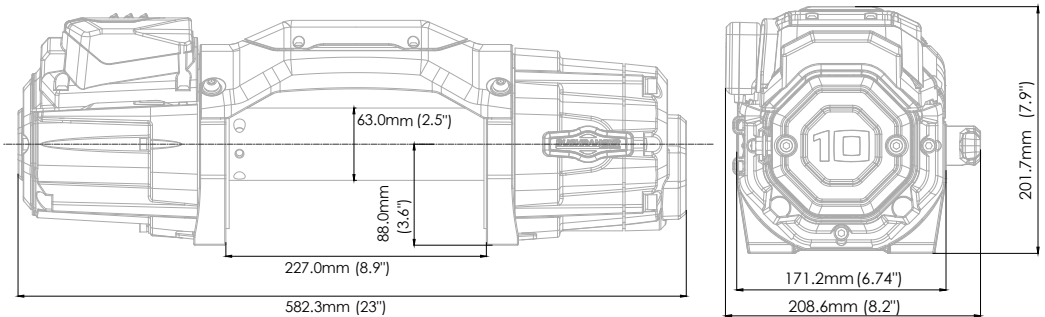

# Installation

It is highly recommended that installation is performed by an authorised technician.

## Winch mounting

- It is very important that the winch is mounted on a flat and hard surface/mounting channel or in a suitably rated winch-compatible bull bar to ensure the motor, drum and gearbox housing are aligned correctly.
- The fairlead is not designed to mount to the winch directly.
- The rope must be wound in an under-wound orientation only.

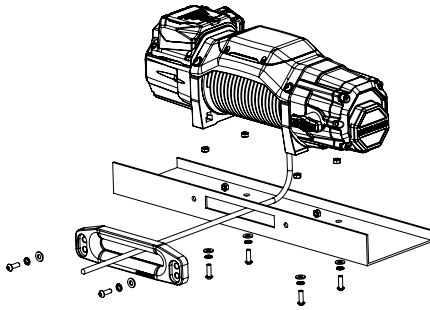

Foot Down Installation

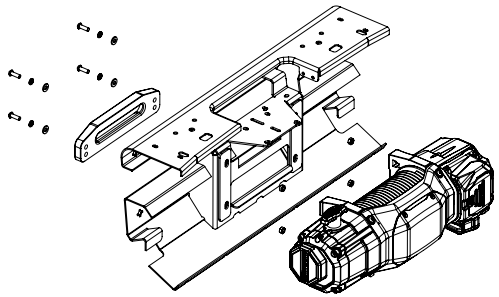

Foot Forward Installation

The winch is provided with a range of bolts to suit different mounting options:

- 4 x M10x35mm Hex Head bolts (for foot down installation)
- 2 x M10x50mm Button Head Bolts (for mounting Hawse Fairlead in foot forward mounting – COVERT 10S only)
- 2 x M10x45mm Button Head Bolts (for mounting Roller Fairlead in foot forward mounting – COVERT 10W only)
- 2 x M10x40mm Button Head Bolts (for mounting Hawse & Roller Fairlead in foot down mounting)
- 6 x M10 Spring Washers
- 6 x M10 Flat Washers
- 4 x M10 Hex Nuts
- 2 x M10 Nyloc Nuts

Note: Four (4) M10 x 1.50 pitch 10.9 grade high tensile steel bolts (supplied) must be used in order to sustain the loads imposed on the winch mounting.

Torque Settings (Maximum)	
M10 x 1.5– 10.9 Grade	44 N.m



## Gearbox Rotation

The gearbox is preset at position 'A' which suits the majority of vehicle fitments, however the gearbox can be rotated in 22.5° increments to allow for the clutch handle to be orientated to best suit the installation requirements.

**Fitment guides for common vehicles are available via [bushranger.com.au](http://bushranger.com.au).**

1. Loosen and partially remove the 4 x bolts (see important note and red arrows below) that secure the two gearbox sections to the winch. **DO NOT** remove the gearbox sections from the winch.
2. Rotate the two gearbox sections and bolts simultaneously (all moving parts highlighted in grey) to achieve the target angle as highlighted below.
3. Reinstall and tighten all bolts to Max 19Nm with torque wrench.

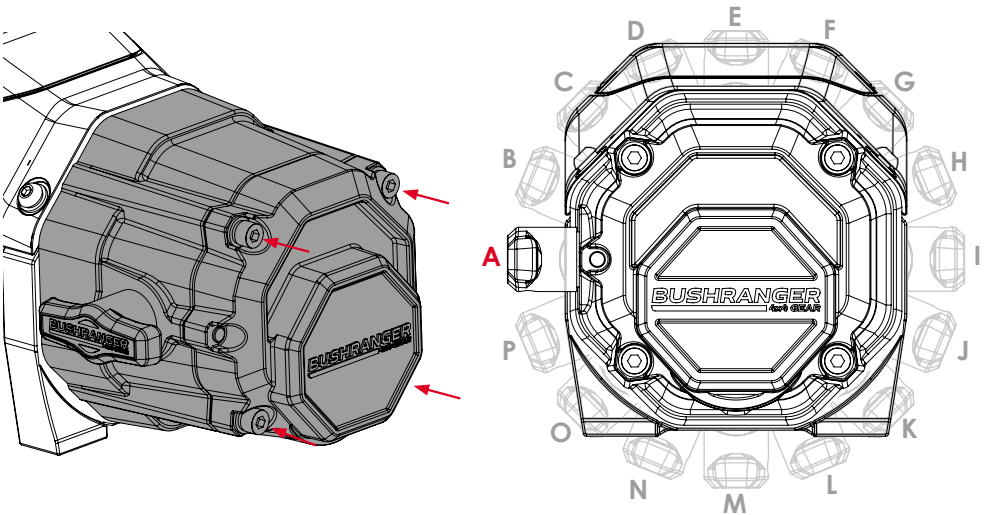

**STEP 1**

**STEP 2**

### Important note:

**DO NOT USE** a Power Tool such as an impact driver. This may lead to the stripping of bolt threads or heads of bolts.

## Motor Rotation

The orientation of the motor assembly is set to the most common position suiting the majority of vehicle fitments. The motor can be rotated to 5 positions in 45° increments to allow for the repositioning of the assembly if there are clearance issues.

1. Loosen and remove the 3 x bolts that secure the motor cover to the drum support. (circled in **red**)
2. Loosen and partially remove the 2 x bolts that secure the motor to the drum support. (circled in **green**)
3. Rotate the entire motor assembly (all moving parts highlighted in grey) on Drum Support to the desired position, ensuring the motor seal reseats into the correct position.
4. Reinstall motor bolts and motor cover bolts and tighten to 10Nm torque.

### STEP 1

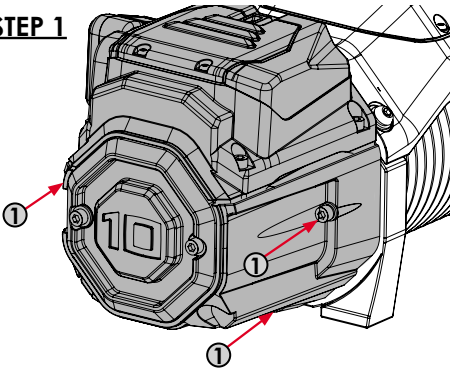

### STEP 2

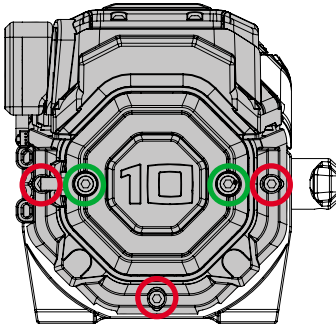
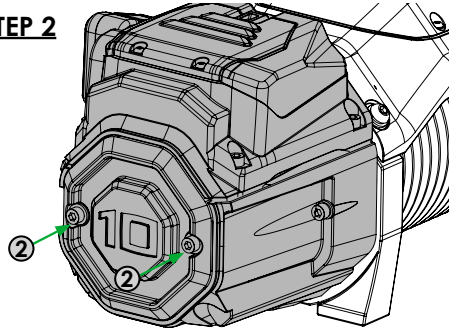

Position 1

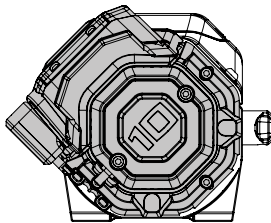

Position 2

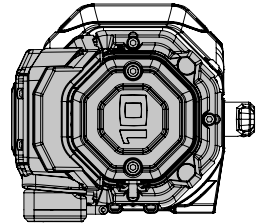

Position 3

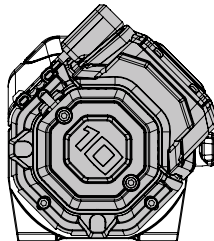

Position 4

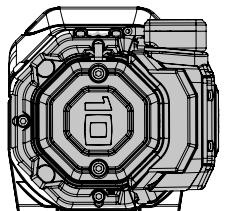

Position 5

### Important Note:

**DO NOT USE** a Power Tool such as an impact driver. This may lead to the stripping of bolt threads or heads of bolts.

## Battery Recommendations

A fully charged battery and good connections are essential for the proper operation of your winch. **The minimum requirement for a 12 Volt DC battery is 650 cold cranking amps.**

- Do not lean over batteries while making connections.
- The earth wire should be disconnected during installation.

## Wiring Diagram

The Bushranger COVERT winch is supplied with the power cables pre-wired to the winch and with a universal fitment isolation switch.

Find a suitable location close to the vehicle's battery to mount the isolation switch utilising the supplied bracket.

Route the main positive (red) wire from the winch to the isolation switch and then from the isolation switch to the positive battery terminal. Connect the main negative (black) wire to the negative battery terminal.

Find a suitable location to mount the winch control plug, either in the bull bar or within an easily accessible location within the engine bay, using the supplied universal bracket.

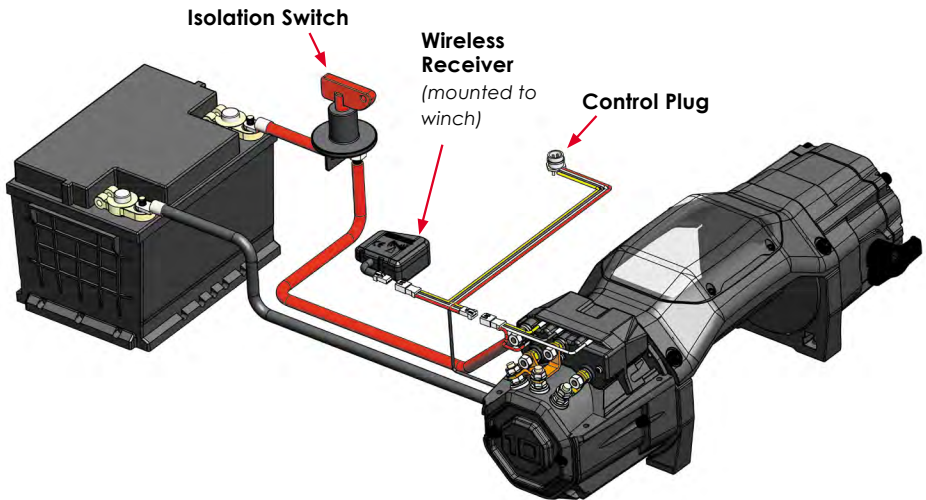

# Operational Checklist (Prior to Use)

---

It is important to check and prepare the winch after installation, to ensure everything is correctly setup and ready for use.

## Installation Checklist

- Check the operation of the isolation switch.
- Check the hand controller connections are functioning.
  - Wired Connection:** Connect the 5m lead from the hand controller plug to the control plug (see page 15).
  - Wireless Connection:** Hold wireless button and await the green light (see page 15)
- Test the Clutch Handle freespool mechanism. (See page 14)
- Rope Preparation (Wire & Synthetic)**

Prior to using the rope for the first time, it must be tensioned onto the drum under load to ensure a tight and uniform wrap is achieved. A rope that is not tensioned and wound tightly and evenly prior to use can be permanently damaged since the outer layers of rope can draw down into the inner layers leading to binding, pinching or wedging between layers.

One method for tensioning the rope onto the drum is to use the weight of the vehicle on a slight incline to pull on the rope while spooling in. This can be achieved by following the steps outlined in the following section "Winch Operation" (Page 14). Prior to spooling in under this load, ensure the rope is pulled out to leave the minimum amount of wraps on the drum (5 wraps for wire rope and 10 wraps for synthetic rope).

Note: There is a red indicator mark on the rope identifying the maximum available length.
- Place the hand controller, 5m lead, red isolation switch key, and these instructions in the glove box (or alternate location in the vehicle cab) together.

# Optional Winch Products/Accessories

It is recommended to use Bushranger winch and recovery products that have been designed and tested alongside this winch.

## Tree Trunk Protector Strap

RTS11

A tree trunk protector strap is useful for connecting a rope to almost any anchor point but is primarily designed to prevent a tree from ring barking. The tree trunk protector should be wrapped around the chosen tree or anchor point as low to the ground as possible and the two ends brought together and joined with a bow shackle. The bow shackle then becomes the recovery point to where the rope or extension strap is joined.

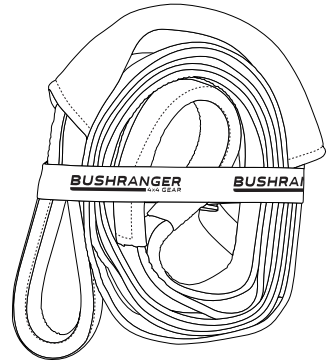

## Snatch Block

RBS11

A snatch block is an important aid to successful winching and can be used to increase the pulling power (or mechanical advantage) of a winch, or change the direction of a pull.

Where a double line pull is used (i.e. where a snatch block is used at the load or anchor point and the winch rope is connected back to the vehicle), twice the pull force is applied but the speed of recovery is halved.

One snatch block can be used in an indirect pull where the vehicle is limited due to unsuitable ground or obstruction. In this instance, the pull on the load is the actual line pull of the winch.

If more than one snatch block is used, they must be located at least 1m (40") apart.

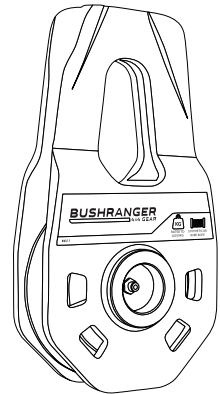

## Recovery Damper

61X05

A recovery damper is a safety device designed to help eliminate the possibility of injury or property damage in the event of a rope failure. Placed in the middle third of a live rope, in the event of the rope breaking, the damper can help absorb the energy in the rope and reduce the likelihood of injury or damage.



## Bow Shackles

58X01K | 58X02K

Only bow shackles that are load rated should be used for vehicle recovery. Load ratings are visible on the shackle and will be in the form of WLL (working load limit) or SWL (safe working load). The shackles, or any other recovery equipment, used should be sized correctly for the winching task.

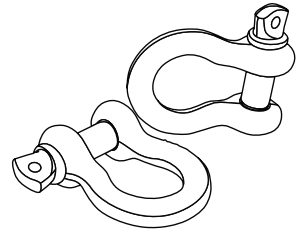

## Winch Extension Strap

RSW05

Used when your rope isn't long enough to reach the recovery anchor point, extension straps are made from polyester webbing and come in various lengths and load ratings to suit varying recovery situations.

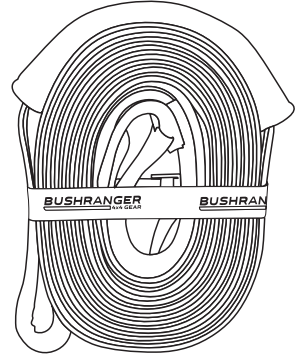

## Bridal/Equaliser Strap

Designed to spread the load of the recovery across two points on the vehicle requiring assistance. Can be used in both Snatch Strap or Winching recoveries.

## Winching Principles

**NOTE:** Bushranger 4X4 Gear recommend that prior to using this recovery equipment, users should undertake formal training from an accredited industry body in winch use and vehicle recovery.

### Calculating Fleet Angle

To obtain the best rope service, the direction of pull should be on a horizontal plane within  $\pm 15$  degrees and perpendicular to the centreline of the winch drum within  $\pm 15$  degrees. If the fleet angle is larger than the recommended angles, incorrect spooling may occur, resulting in the rope loading onto one side of the rope drum and possible damage to the rope or winch.

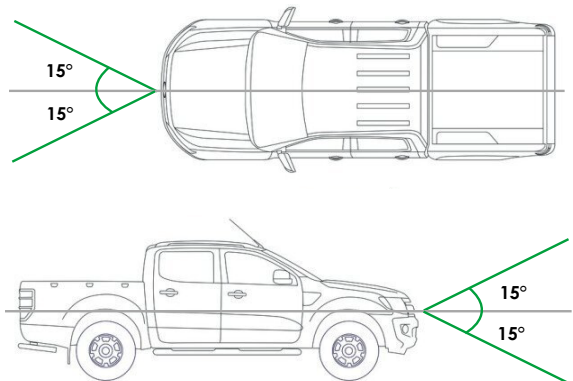

## Required Pulling Force

Your winch must be powerful enough to overcome the resistance caused by an obstacle, such as moving water, mud, snow, sand or on a steep hill, as well as pulling the vehicle's full weight.

As a general guide, you need a winch with a maximum line pull at least 1.5 times greater than the gross vehicle weight.

There are three factors listed that have influence on the line pull effect required to recover the vehicle. The values and calculations in this section are approximate and are for reference only.

- a) Gross vehicle mass (GVM)
- b) Type of surface to be traversed
- c) Gradient to overcome

In recovery and loading, where the winch is used to pull something, the required pulling force (RPF) can be calculated according to the formula:

$$RPF = (Wt \times S) + (Wt \times G)$$

Where:

- Wt = the gross vehicle mass (GVM)
- S = the type of surface to be traversed
- G = the gradient to overcome

Surface Type	Surface Drag (S)
Metal	0.15
Sand	0.18
Gravel	0.20
Soft Sand	0.22
Mud	0.32
Marsh	0.52
Clay	0.52

Gradient	Angle (θ)	Gradient (G)
5%	3°	0.06
10%	6°	0.11
20%	11°	0.2
30%	17°	0.3
50%	26°	0.44
70%	35°	0.58
100%	45°	0.71

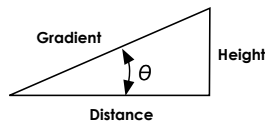

For example, if a vehicle weighing 3,000kg is winched up an incline of 100% on a marshy surface, the above formula would be used as follows:

Where            Wt: 3,000kg,            S: 0.52            G: 0.71

$$\begin{aligned}
 RPF &= (Wt \times S) + (Wt \times G) \\
 &= (3,000\text{kg} \times 0.52) + (3,000\text{kg} \times 0.71) \\
 &= 1,560\text{kg} + 2,130\text{kg} \\
 &= 3,690\text{kg of effect required to recover the vehicle.}
 \end{aligned}$$

Note: A gradient of 10% is a rise of one metre in ten metres (Height/Distance).

## Duty Cycle Ratings

Duty cycle ratings usually specify continuous, intermittent, or special duty (typically expressed in minutes). The IEC (International Electrotechnical Commission) lists the following ratings:

- S1 - Continuous duty  
The motor works at a constant load for enough time to reach temperature equilibrium.
- S2 - Short-time duty  
The motor works at a constant load, but not long enough to reach temperature equilibrium, and the rest periods are long enough for the motor to reach ambient temperature.
- S3 - Intermittent periodic duty  
Sequential, identical run and rest cycles with constant load. Temperature equilibrium is never reached. Starting current has little effect on temperature rise.

**All automotive winches are rated at S3 intermittent periodic duty.**

## Load Rating

Load and speed vary according to much rope is on the drum. The first layer of rope on the drum delivers the slowest speed and the maximum load. A full drum delivers the maximum speed and the minimum load. For this reason, automotive winches are rated at their first layer capacities

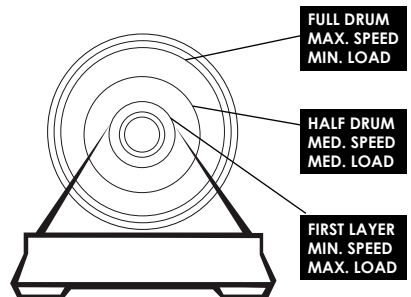



# Winch Operation

---

## Important notes before operating the winch

### Clutch Operation

The unique proportional brake in the winch allows for effortless powering OUT under NO LOAD, with no concern for damage occurring to the brake or motor. In most circumstances powering out the rope may be quicker and easier than free spooling by hand. However if you wish to use the clutch handle for freespooling, familiarise yourself with the operation. The clutch handle either "Engages" the winch for operation or "Disengages" the winch for free spooling of the rope. The clutch must always be "Engaged" before operating the winch under power.

- 1) To disengage, lift and turn the clutch handle 90° in a clockwise direction to the "Disengaged" position. The rope can now free spool off the drum.
- 2) To engage, turn the clutch handle 90° in a counter-clockwise direction to the "Engaged" position.
- 3) If the clutch handle cannot be properly locked in the "Engaged" position, rotate the drum to allow the clutch mechanism to engage the gear train.
- 4) Wear appropriate gloves and use a pull strap when guiding the rope off the drum.
- 5) Never disengage the clutch while the rope is under load. The clutch handle must be returned to the "Engaged" position before winching.

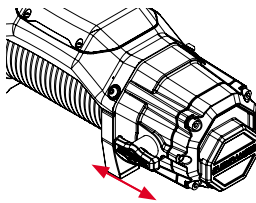

Engaged

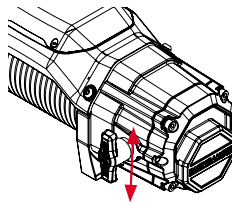

Disengaged

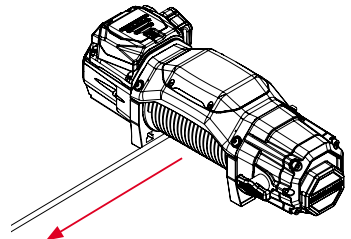

### Powering Out (No Load)

The unique Proportional Brake in the Bushranger COVERT winch allows for effortless powering OUT under NO LOAD, with no concern for damage occurring to the brake or motor. In most circumstances powering out the rope may be quicker and easier than free spooling by hand.

### Powering Out (Under Load)

It is not recommended to power OUT the winch rope UNDER LOAD for longer than 30 seconds. Exceeding this time will cause high amounts of wear to the brake.

## Cable-in/Cable-out Operation

The hand controller is paired to the winch as standard and will operate in wireless mode immediately.

### **Wireless Mode**

#### Activating Wireless Mode

Press and hold the Wireless Power Button  for 3 seconds to activate the Wireless Control.

The WIRELESS light will illuminate to indicate you are in WIRELESS mode. To turn off, press and hold the Wireless Power Button  for 3 seconds until the WIRELESS light turns off. The controller is also equipped with an automatic power off function. If the hand controller is not operated for 2 minutes it will turn off automatically to conserve battery power.

**To "Winch - Out",** Press and hold the "OUT" Button

**To "Winch - In",** Press and hold the "IN" Button

**To stop winching,** release the button.

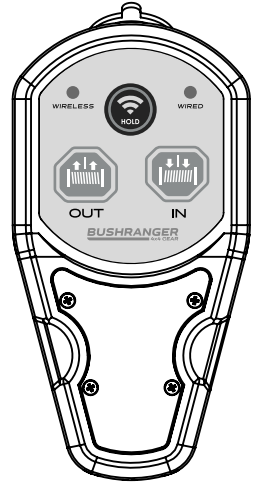

#### Pairing of new Hand Controller

In the case a replacement winch hand controller is required;

1. Ensure the pre-connected hand controller and the winch power is turned off via the isolation switch.
2. Turn on the hand controller to Wireless Mode by pressing the  button for 3 seconds until the Wireless Light flashes green.
3. Press and hold the IN and OUT buttons simultaneously. Both the Wireless and Wired lights will go solid. Continue to HOLD until both lights flash slowly.
4. Whilst still holding the IN and OUT buttons – Turn ON power to the winch via the isolation switch.
5. Release the IN and OUT buttons. The Wireless and Wired lights will flash fast and pairing is complete.

#### Changing battery in the Hand controller

To replace the battery, remove the screws in the front panel of the hand controller. Replace the A23 battery and reassemble the hand controller. When reassembling the hand controller, ensure that the rubber seal is aligned and not pinched.

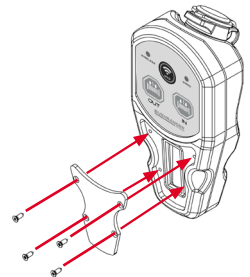

### **Wired Mode**

The wireless hand controller can also be used in wired Mode. Connect the winch hand controller cable to the control plug and the hand controller. When the cable is plugged in, the "Wired" light will illuminate RED.

## Basic Winching Process

### 1) Establish an Anchor Point

When choosing an anchor point, select a firm point such as a tree, stump or rocks. DO NOT WRAP THE ROPE AROUND THE ANCHOR POINT AND BACK ONTO ITSELF. Always use a tree trunk protector strap to prevent ring barking the tree and damage to the rope. If using a winch to retrieve another stranded vehicle, the rescue vehicle is considered the anchor point and should be made secure. The anchor point must be strong enough to hold the gross weight of the vehicle and be positioned to keep the fleet angle between the centre of the anchor point and the wire rope maintained at less than 15°.

### 2) Turn on Power to the Winch

Turn power ON to the winch via the red isolation switch, located close to your vehicles battery. Insert the red key and turn 90° to enable the electrical connection.

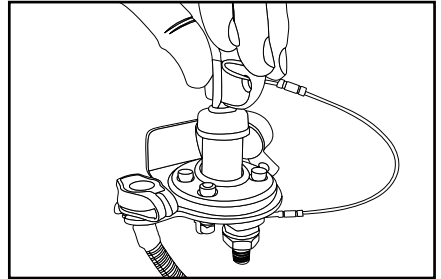

### 3) Turn on the Hand Controller

Connect the hand controller either wirelessly (see page 15) or via the control plug lead. Always disconnect the hand controller when not in use.

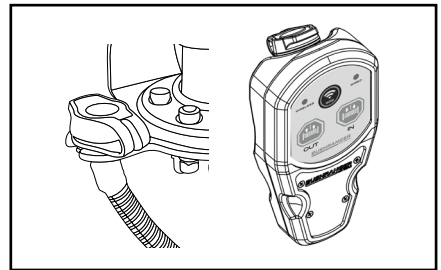

### 4) Disengage the Clutch (for freespool operation)

Lift and turn the clutch handle in a clockwise direction to the "Disengaged" position. The rope is now free to be unwound from the drum by hand. Never disengage the clutch while the rope is under load. Do not disengage the clutch if powering out in Step 3.

**Please note:** The Bushranger COVERT winch can be powered out under no load, and in most situations it may be faster. Pay careful attention not to allow the rope to become "over wound" on the drum when powering out.

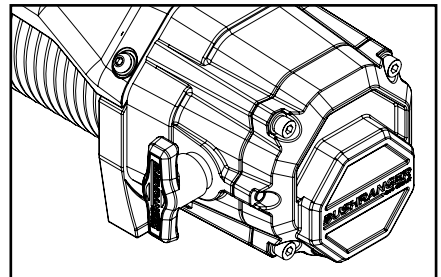

### 5) Pull or Power Out the Rope to the Anchor Point

Wear appropriate gloves when handling rope. Hold the Pull Strap and pull or power out enough rope to reach the anchor point. Keep tension on the rope when unspooling.

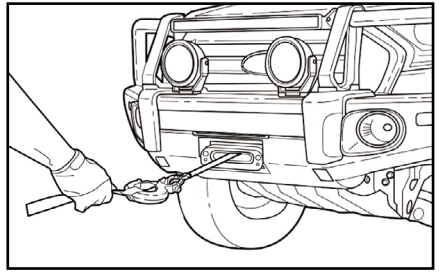

### 6) Engage the Clutch (if freespooled)

To engage, lift and turn clutch handle in a counter-clockwise direction to the "Engaged" position. Never engage the clutch while the drum is rotating. The drum may need to be rotated slightly by hand to ensure proper engagement.

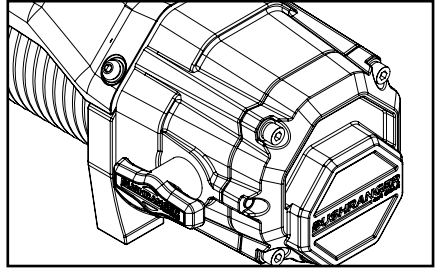

### 7) Check the Rope

Before winching, ensure the rope is wound on the drum evenly. If unevenly wound, there is a possibility of damaging the rope when under load. Visually check rope for any signs of damage.

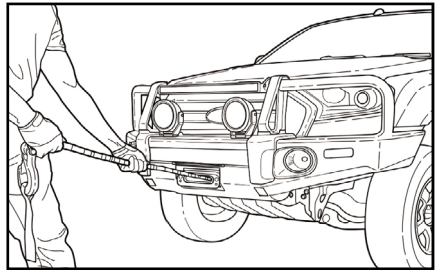

### 8) Attach the Shackle and Hook

Use a shackle to lock both ends of the tree trunk protector and then attach to the hook.

**Please note:** The winch line is now live. Do not step over or cross the rope.

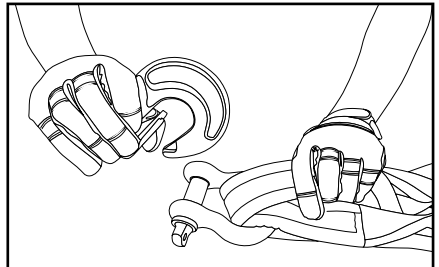

### 9) Use a Recovery Damper

Lay a recovery damper or heavy blanket over the rope in the middle third of its length. If a rope failure occurs, the damper can prevent the rope from whipping.

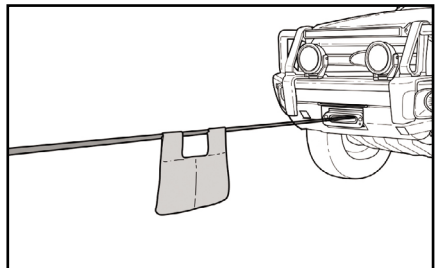

### 10) Prepare the Vehicle

The recovery vehicle's engine should be running to provide maximum power to the winch. The transmission should be set in neutral and the hand brake applied to prevent the vehicle from moving.

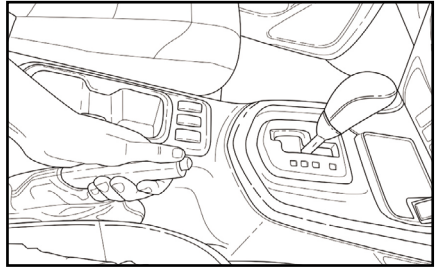

### 11) Begin Winching

Keep tension on the rope to ensure it winds onto the drum tightly and evenly and does not sink into the lower layers. Release Hand brake and continue pulling until the vehicle is recovered.

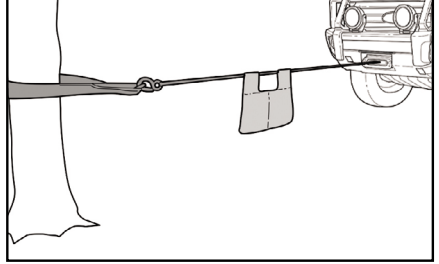

### 12) After Winching

Once the vehicle is recovered and safely secured, wind the remaining rope back onto the drum tightly and evenly and secure the hook firmly. Check rope/parts for wear or damage.

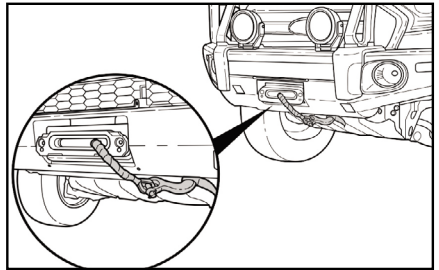

### 13) Disconnect the Hand Controller

Disconnect the wireless mode (See page 15), or unplug the hand controller cable at both ends. Store the hand controller in a safe, dry and easily accessible place.

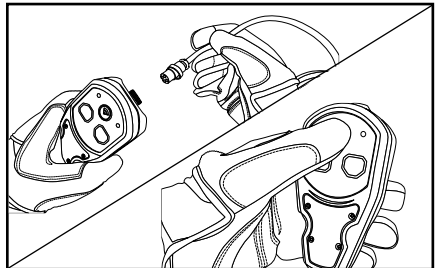

## Precautions Whilst Winching



- Make sure the rope is wound onto the drum tightly and evenly. Allowing the rope to become loosely wound can result in binding, pinching and wedging between layers, ultimately damaging the rope, shortening its life and increasing the risk of injury and failure under load.

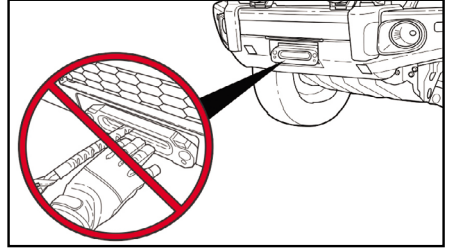

- Always keep clear of the winch, rope, hook and fairlead while winching.

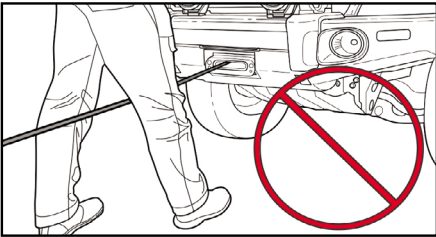

- Keep winching area clear. Do not allow people to remain in the area while winching. Never step over a live rope whilst under load.

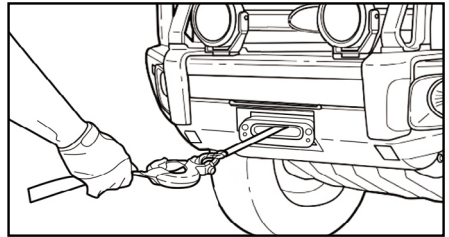

- Never guide a rope onto the drum with your hand. Use the supplied Pull Strap.

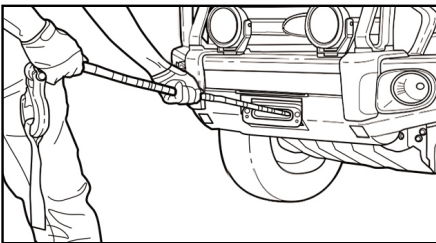

- Avoid the hand controller cable from coming in to contact with the winch, rope or fairlead, as damage to the cable may result.

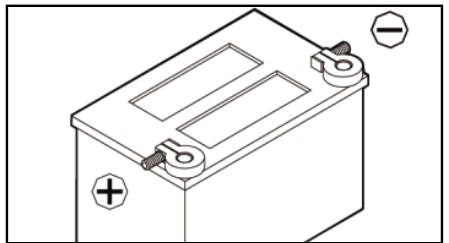

- A winching operation requires extra consumption of battery power, so always maintain your battery and ensure it is in good condition.

# Maintenance

---

## Cleaning

Only use low pressure water to clean the synthetic rope. Do not use any chemicals. We recommend using low pressure water and a soapy sponge to clean the winch. If high pressure water is used, do not direct it at the drum area or the clutch handle. Using high pressure water in these areas can force water past seals and lead to internal water build up which can damage the winch.

## Tips for Prolonging the Life of Synthetic Rope

1. Periodically check the rope for damage or wear. Frayed, kinked or damaged winch rope must be replaced immediately.
2. When the rope is used for the first time, the outer filaments may fray. This is a result of the outer filaments breaking. The roughened surface will actually protect the inner fibres.
3. Inspect both inner and outer fibres. Open the strands and look for powdered fibre. This is a sign of internal wear.
4. Protect your rope from rubbing against sharp or abrasive objects.
5. Keep your synthetic rope clean and dry. To clean it after use in muddy conditions, spool out the rope, rinse it with fresh water and let it dry completely before re spooling.
6. All synthetic ropes are affected by UV rays, chemicals, abrasion and heat. Once the synthetic rope has begun to deteriorate the breaking strength is compromised. It is recommended that synthetic rope is replaced every 12 months once fitted or UV exposed

## Servicing

Servicing and repairs should only be carried out by an authorised dealer. Unauthorised repairs or servicing will void warranty. The maintenance scheduled should be followed to ensure reliable operation for the life of the winch.

The winch should be used regularly to ensure components are kept in good working order. At a minimum, it is recommended that the rope is powered out and then powered back in on a monthly basis by following the correct winching procedures (Page 14). The drum support seals are a wearing item and are critical to retaining the sealed design of the winch. These should be inspected and greased or replaced as required depending on the frequency of use and the operational environment.

All moving parts in the winch are permanently lubricated at the time of assembly. Under normal conditions, factory lubrication will suffice. If re-lubrication of the gear box is necessary after repair or disassembly, use Shell EP2 or equivalent grease. The clutch handle can be lubricated regularly with light oil.

## Maintenance Schedule

1. Ensure that a responsible person carries out all inspections as per schedule.
2. Inspections are divided into Daily, Monthly and Three Months.

Classification of check			Item	Checking Method	Checking Reference	
Daily	Periodical					
	One month	Three months				
○			Installation	Mounting bolts & alignment	Bolt tension & wear	Existence of abnormalities
○			Remote control	Correct operation	Manual	Reasonable actuation
○			Wire rope	Broken strands	Visual, measuring	Less than 10%
○	○			Decrease in rope diameter	Visual, measuring	7% of nominal diameter max
○				Deforming or corrosion	Visual	Existence of abnormalities
○				Fastening to hook and drum assemblies	Visual	Existence of abnormalities
○						
○			Synthetic rope	Broken strands	Visual, measuring	Two or more adjacent strands are cut
○	○			Decrease in rope diameter	Visual, measuring	25% of nominal diameter max
○				Fused or melted fibres	Visual	Existence of abnormalities
○				Fastening condition of end	Visual	Existence of abnormalities
		○	Clutch assembly	Damaged clutch assembly	Visual evidence of wear	Free of wear or damage
		○	Motor	Staining, damage	Visual evidence of wear	Existence of abnormalities
○			Brake	Ability to hold loads	Visual	Reasonable actuation
		○	Gears	Smooth operation	Visual, auditory	Reasonable actuation
		○	Seals	Damaged or worn seals	Visual evidence of wear	Free of wear or damage

## Synthetic Rope Replacement | RWCA004

Always use a replacement rope that is correctly rated for the capacity of the winch. Use the following method to replace the synthetic rope:

1. Disengage the clutch handle.
2. Spool out the entire synthetic rope, loosen the set screw and then remove rope from the drum and replace the hawse fairlead if necessary.
3. If the end of the rope is not shrink wrapped, cut the lateral side of the end of the rope at a 45° angle and apply 2-3 wraps of electrical tape to the end to hold cut strands in place.
4. Thread the rope through the hawse fairlead and under the drum, then insert the rope all the way through the hole in the end of the drum with 15-20cm protruding out.



5. Place the protruding section of rope across the drum and tape the end down to hold it in place. Lightly tighten the set screw to squeeze the rope. Do not over tighten.
6. Fit the clevis hook to the thimble end of the rope and ensure the split/cotter pin is correctly installed to secure the pin.
7. Wind the red section of rope onto the drum tightly and evenly (under hand tension) to have a minimum of ten (10) wraps of wire rope on the drum.
8. Follow the procedure outlined in the previous sections "Rope Preparation" (Page 9) and "Winch Operation" (Page 14) to complete the installation of the replacement synthetic rope.
9. A minimum of ten (10) wraps of synthetic rope around the drum is necessary to support the rated load.
10. A red painted section of the rope warns the operator that there is 3 meters of rope left on the drum. Do not wind out past this point.

## Wire Rope Replacement | RWCA001

Always use a replacement rope that is correctly rated for the capacity of the winch. Use the following method to replace the wire rope:

1. Disengage the clutch handle.
2. Spool out the entire wire rope, loosen the set screw and then remove the rope from the drum.
3. Feed the replacement wire rope through the roller fairlead opening, pass below the drum, and insert it into the hole on the drum end. Tighten the set screw to secure the wire rope.
4. Fit the clevis hook to the thimble end of the rope and ensure the split/cotter pin is correctly installed to secure the pin.
5. Wind the red section of rope onto the drum tightly and evenly (under hand tension) to have a minimum of five (5) wraps of wire rope on the drum.
6. Follow the procedure outlined in the previous sections "Rope Preparation" (Page 9) and "Winching Procedures" (Page 14) to complete the installation of the replacement wire rope.
7. A minimum of five (5) wraps of wire rope around the drum is necessary to support the rated load.
8. A red painted section of the rope warns the operator that there is 3 meters of rope left on the drum. Do not wind out past this point.

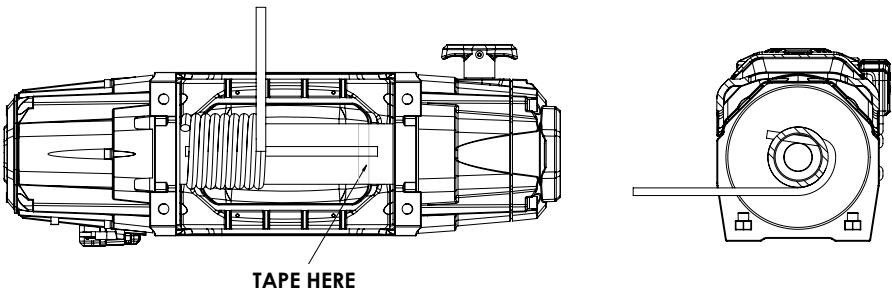

# Troubleshooting

If the winch fails to operate after several attempts, or if there is any fault whilst operating:

Symptom	Possible Cause	Remedy
Winch will not operate	Cut circuit	Check battery lead
	Weak battery	Recharge or replace battery (at least 650CCA)
	Bad connection of wirings	Reconnect tightly
	Damaged contactor	Replace contactor
	Cut circuit on switch	Replace switch
	Damaged motor or worn brushes	Replace motor or brushes
	Faulty motor wirings	Replace wirings
Motor runs in only one direction	Broken wirings or bad connections	Reconnect or replace wirings
	Damaged or stuck contactor	Replace contactor
	Switch inoperative	Replace switch
	Faulty wiring	Replace wiring
Drum will not free spool	Clutch does not disengage	Engage clutch
	Damaged 1st stage shaft	Replace 1st stage shaft
	Damaged brake	Replace brake
	Damaged motor output shaft	Replace motor output shaft
Brake fails to operate	The gear train is mechanically binding up	Check to insure the winch is mounted on a flat, rigid surface
	Damaged brake	Replace brake
	Damaged gear box	Replace gear box
	Damaged ratchet	Replace ratchet components
Braking distance is too long	Worn brake	Replace brake
Brake jam	Proportional mechanism is damaged or worn	Replace
Damaged gear box	Hit by certain exterior force	Replace the damaged components
	Damaged gear train	Replace the damaged components
	Over load operation	Stop the winch operation and reduce a load
Motor runs extremely hot	Long period of operation	Allow to cool
	Damaged motor	Replace or repair motor
	Damaged or inoperative brake	Replace or repair brake

# Winch Assembly - Covert 10 Synthetic

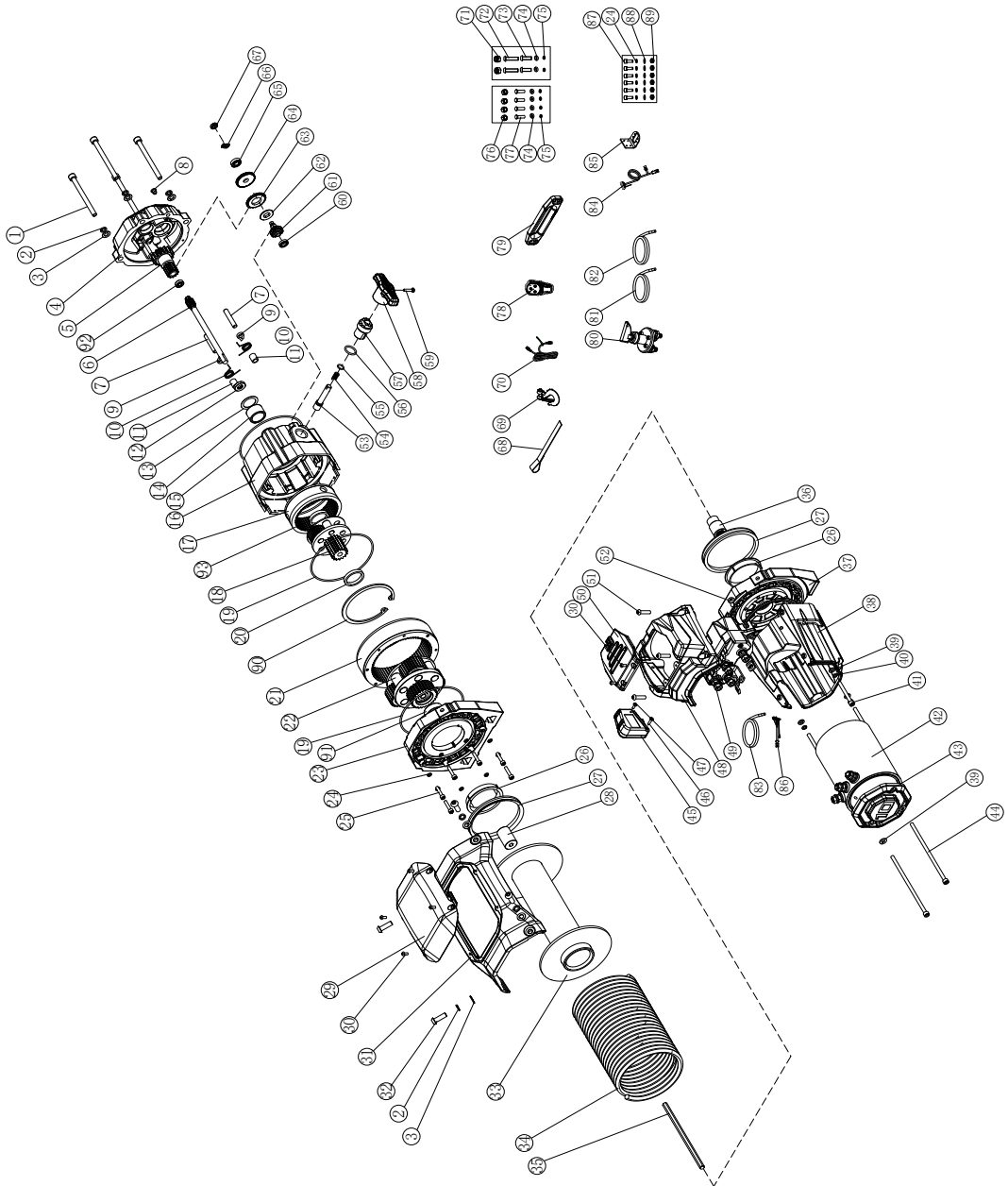

Item No:	Description	Qty
49	Albright Contactor	1
50	Control box top cover	1
51	Hexagon socket cap screw M6*25	4
52	Cross recessed pan head screw M6*16	2
53	Clutch Pin	1
54	Clutch Spring	1
55	O Ring Seal $\phi 10 \times \phi 1.8$	1
56	O Ring Seal $\phi 19 \times 2.65$	1
57	Clutch Cam	1
58	Clutch Handle	1
59	Cross recessed pan head screw M4*20	1
60	Second Stage Bearing	1
61	Second Stage Pinion Shaft	1
62	Friction Brake Block	1
63	Ratchet Gear With Friction Pad	1
64	First Stage Ratchet Gear	1
65	Ratchet Bearing	1
66	Stop Washer M12	1
67	Nut M12*1.25	1
68	Hand Strap	1
69	Synthetic Rope 3/8"Hook	1
70	Remote Control Cable	1
71	M10 Nyloc Nut	2
72	Hexagon socket flat head screw M10*50	2

Item No:	Description	Qty
73	Hexagon socket flat head screws M10*40	2
74	Flat Washer $\phi 10$	6
75	Spring Washer $\phi 10$	6
76	Winch Mounting nut M10	4
77	M10*35mm Hex Head Screw	4
78	Hand Controller	1
79	Hawse fairlead	1
80	Isolation switch	1
81	Red AWG2 cable 300mm	1
82	Black AWG2 cable 1800mm	1
83	Red AWG2 cable 1500mm	1
84	T Harness	1
85	Isolation switch bracket	1
86	contactor wires	1
87	Hexagon socket cap screw M5*20	6
88	Flat Washer $\phi 5$	6
89	Hexagon nut M5	6
90	Third Stage Retaining Circlip	1
91	Input Shaft Bearing	1
92	Gearbox Cover Ratchet Bearing	1
93	Anti-Wear Washer	1

# COVERT 10 Synthetic Model Parts List

No.	Description	Qty
1	Gearbox End Socket Head Cap Screw M8*100	4
2	Spring Washer φ8	8
3	Flat Washer φ8	8
4	Gearbox End Cover	1
5	Third Stage Sun Gear	1
6	First Stage Gear Shaft	1
7	Pawl PIN	2
8	Rubber plug for clutch	1
9	Pawl	2
10	Spring	2
11	Pawl Spacer Bush	2
12	First Stage Anti-Wear Washer	2
13	Bearing Anti-Wear Washer	1
14	Needle Roller Bearing	1
15	O Ring Seal 122*2.65	1
16	Gearbox Housing Second Stage	1
17	3rd Stage Rotating Ring Gear	1
18	Third Stage Planetary Gear Assembly	1
19	O Ring Seal 125*2.65	1
20	Third Stage Anti-Wear Washer	2
21	Fourth Stage Ring Gear	1
22	Fourth Stage Planetary Gear Assembly	1
23	Drum Support Gearbox Side	1
24	Spring Washer φ5	8

Item No:	Description	Qty
25	Hexagon socket cap screw M5*25	8
26	Drum Bearing	2
27	Drum Support Seal	2
28	Shaft Coupler	1
29	Tie bar top cover	1
30	Hexagon socket cap screw M4*10	6
31	Tie bar	1
32	Hexagon socket cap screw M8*25	4
33	Drum assembly	1
34	Synthetic rope 10mm*28m	1
35	Motor Output Shaft	1
36	Motor Coupling	1
37	Drum Support Motor Side	1
38	10K Motor Cover	1
39	Flat Washer φ6	6
40	Spring Washer φ6	4
41	Hexagon socket cap screw M6*55	4
42	10K Motor Assembly	1
43	Motor End Cover	1
44	Motor Mounting Hexagon Head Bolts M6*156mm	2
45	Receiver	1
46	Cross recessed pan head tapping screw 3.5*16	1
47	Cross recessed pan head tapping screw 3.5*12	1
48	Control Box Cover	1

# Winch Assembly - Covert 10 Wire

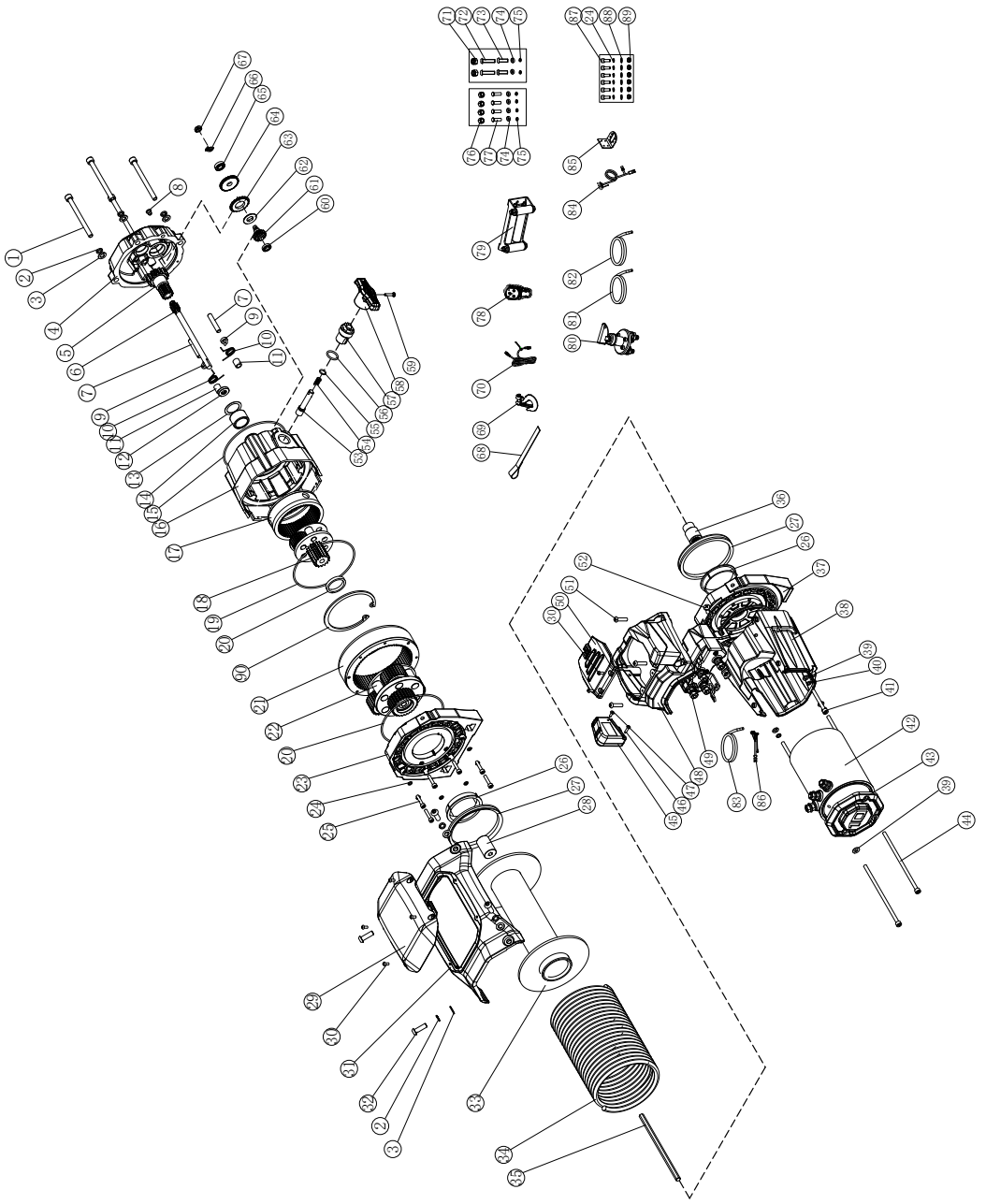

# COVERT 10 Wire Model Parts List

Item No:	Description	Qty
1	Gearbox End Socket Head Cap Screw M8*100	4
2	Spring Washer φ8	8
3	Flat Washerφ8	8
4	Gearbox End Cover	1
5	Third Stage Sun Gear	1
6	First Stage Gear Shaft	1
7	Pawl PIN	2
8	Rubber plug for clutch	1
9	Pawl	2
10	Spring	2
11	Pawl Spacer Bush	2
12	First Stage Anti-Wear Washer	2
13	Bearing Anti-Wear Washer	1
14	Needle Roller Bearing	1
15	O Ring Seal 122*2.65	1
16	Gearbox Housing Second Stage	1
17	3rd Stage Rotating Ring Gear	1
18	Third Stage Planetary Gear Assembly	1
19	O Ring Seal 125*2.65	1
20	Third Stage Anti-Wear Washer	2
21	Fourth Stage Ring Gear	1
22	Fourth Stage Planetary Gear Assembly	1
23	Drum Support Gearbox Side	1
24	Spring Washer φ5	14

Item No:	Description	Qty
25	Hexagon socket cap screw M5*25	8
26	Drum Bearing	2
27	Drum Support Seal	2
28	Shaft Coupler	1
29	Tie bar top cover	1
30	Hexagon socket cap screw M4*10	6
31	Tie bar	1
32	Hexagon socket cap screw M8*25	4
33	Drum assembly	1
34	Wire rope 9.2mm*28m	1
35	Motor Output Shaft	1
36	Motor Coupling	1
37	Drum Support Motor Side	1
38	10K Motor Cover	1
39	Flat Washer φ6	6
40	Spring Washer φ6	4
41	Hexagon socket cap screw M6*55	4
42	10K Motor Assembly	1
43	Motor End Cover	1
44	Motor Mounting Hexagon Head Bolts M6*156mm	1
45	Receiver	1
46	Cross recessed pan head tapping screw 3.5*16	1
47	Cross recessed pan head tapping screw 3.5*12	1
48	Control Box Cover	1

Item No:	Description	Qty
49	Albright Contactor	1
50	Control box top cover	1
51	Hexagon socket cap screw M6*25	4
52	Cross recessed pan head screw M6*16	2
53	Clutch Pin	1
54	Clutch Spring	1
55	O Ring Seal $\phi 10 \times \phi 1.8$	1
56	O Ring Seal $\phi 19 \times 2.65$	1
57	Clutch Cam	1
58	Clutch Handle	1
59	Cross recessed pan head screw M4*20	1
60	Second Stage Bearing	1
61	Second Stage Pinion Shaft	1
62	Friction Brake Block	1
63	Ratchet Gear With Friction Pad	2
64	First Stage Ratchet Gear	1
65	Ratchet Bearing	1
66	Stop Washer M12	1
67	Nut M12*1.25	1
68	Hand Strap	1
69	Synthetic Rope 3/8"Hook	1
70	Remote Control Cable	1
71	M10 Nyloc Nut	2
72	Hexagon socket flat head screw M10*50	2
73	Hexagon socket flat head screws M10*40	2

Item No:	Description	Qty
74	Flat Washer $\phi 10$	6
75	Spring Washer $\phi 10$	6
76	Winch Mounting Nut M10	4
77	M10*35mm Hex Head Screw	4
78	Hand Controller	1
79	Roller fairlead	1
80	Isolation switch	1
81	Red AWG2 cable 300mm	1
82	Black AWG2 cable 1800mm	1
83	Red AWG2 cable 1500mm	1
84	T Harness	1
85	Isolation switch bracket	1
86	contactor wires	1
87	Hexagon socket cap screw M5*20	6
88	Flat Washer $\phi 5$	6
89	Hexagon nut M5	6
90	Third Stage Retaining Circlip	1
91	Input Shaft Bearing	1
92	Gearbox Cover Ratchet Bearing	1
93	Anti-Wear Washer	1



# KINGSLEY PRODUCTS - WARRANTY POLICY

## 1. Our Warranty

We warrant to you that the Kingsley product is free from defects in workmanship and materials for the warranty period.

## 2. Fitting and use

Please ensure you:

a. Fit the Kingsley product in accordance with the product information and all relevant vehicle safety and compliance laws

b. Use the Kingsley product for the purpose for which it was originally designed and in accordance with the product information and all relevant vehicle safety and compliance laws

## 3. Exclusions

Our warranty doesn't cover:

a. Normal wear and tear

b. Wear from the use of synthetic or wire ropes.

c. Surface finish from use

d. Fitting the Kingsley product other than in accordance with the product information and any relevant vehicle safety and compliance laws, including incorrect fitting

e. Using the Kingsley product other than for the purpose for which it was originally designed or other than in accordance with the product information and any relevant vehicle safety and compliance laws, including unusual, improper or negligent use or misuse or overloading

f. Misuse or neglect of the Kingsley product, including improper repair or maintenance or failing to repair or maintain

g. Alteration, abuse, acts of nature, terrorism, vandalism, collision, road hazards or adverse conditions

h. Removal or re-installation of the winch

## 4. Making a claim

Please immediately contact us as soon as you become aware of a possible defect in the Kingsley product. We'll arrange for you to either attend a Kingsley outlet (at your cost) for a Kingsley representative to inspect the Kingsley product (as fitted to your vehicle) or for you to return the Kingsley product to us. We'll also request you to provide the purchase receipt and complete a warranty claim form. In order to ensure our warranty is not voided, please keep the purchase receipt as proof of purchase and don't remove the fitted Kingsley product from your vehicle before contacting us. Note: Non-transferable warranty. The original purchaser can only claim warranty. If your claim's in order, we'll notify you and (at our sole discretion) either repair or replace the defective workmanship or materials (at our cost) or refund to you the purchase price you paid for the defective Kingsley product. If further information or investigation is required or if the claim does not meet the requirements under our warranty, we'll let you know.

### 1. Australian Consumer Law

The Kingsley product comes with guarantees that can't be excluded under the Australian Customer Law. You're entitled to a replacement or refund if there's a major failure and compensation for any other reasonably foreseeable loss or damage. You're also entitled to have the Kingsley product repaired or replaced if it fails to be of acceptable quality and the failure doesn't amount to a major failure.

### 2. Other consumer rights

The benefits to you under our warranty are in addition to any other rights and remedies you are entitled to under relevant consumer laws. Our warranty replaces any other warranty given by Kingsley or it's supplier in respect of the Kingsley product.

### 3. Terms

The following terms have the following meanings:

Term	Meaning
Product information	Information about the Kingsley product which may be contained in any of the documentation provided with the Kingsley product, including safety instructions, installation instructions, operating instructions, owner's manual, service manual, labels and packaging
Purchase date	The date you purchased the Kingsley product from a Kingsley outlet, as specified in the purchase receipt
Kingsley outlet	An outlet authorised by Kingsley to sell Kingsley products
Kingsley products	Products or components which Kingsley manufactures or sells through Kingsley outlets
Warranty period	Commences on and from the purchase date and ends as follows: <b>Limited Lifetime Warranty (7 Year Warranty on Electrical components).</b>
We/Us	Kingsley Enterprises Pty Ltd (ABN 23 001 592 749) E: sales@bushranger.com.au A: 6A Brooks Road, Ingleburn NSW 2565 P: 1800 654 767 W: www.bushranger.com.au
You	The purchaser of the Kingsley product from a Kingsley outlet



# COVERT

[www.bushranger.com.au/winch](http://www.bushranger.com.au/winch)

**BUSHRANGER**  
4x4 GEAR

**Kingsley Enterprises PTY. LTD.**

Free Call | 1800 654 767 (Australia Only)

International | +61 2 8700 0400

Email | [sales@bushranger.com.au](mailto:sales@bushranger.com.au)

Address | 6A Brooks Road, Ingleburn NSW 2565

0275-220