

**BUSHRANGER**  
4x4 GEAR

RWM100S | RWM100W | RWM120S | RWM120W



REVO

# MKII

VEHICLE RECOVERY WINCH

OWNERS MANUAL

REVO

# MK II

## VEHICLE RECOVERY WINCH

Congratulations on the purchase of your Bushranger vehicle recovery winch. Be proud that this product has been designed and thoroughly tested in Australia to meet the specified applications (see limitations in 'Warnings & Safety') and with proper care and preventative maintenance, will give you years of trouble-free operation. All information in this publication is based on the latest production information available at the time of print. We reserve the right to make changes without notice because of continued product improvement.

Your Bushranger winch has been designed to give safe and dependable service if operated according to the instructions. Please read and understand this manual before installation and operation of the winch. Careless winch operation can result in serious injury or property damage.

When requesting information or ordering replacement parts, always give the following information:

1. Winch model and voltage
2. Serial Number
3. Item. No. and Part Number
4. Part Description

Warnings & Safety .....	4
Specifications .....	6
Installation .....	10
Operational Checklist (Prior to use) .....	16
Winch Products/Accessories .....	17
Winching Principles .....	18
Winch Operation .....	21
Maintenance .....	28
Troubleshooting .....	32
Winch Assembly & Parts List .....	33
Warranty .....	45



## **CAUTION! READ USER MANUAL BEFORE OPERATION OR INSTALLATION.**

Do not operate or install without understanding these instructions and having a working knowledge of winching techniques.



### **Warnings**

1. It is highly recommended that prior to using this vehicle recovery winch, that users undertake off road training including vehicle recovery. Recovering immobilised vehicles is a potentially dangerous exercise, this winch is to be used with great care.
2. The winch is rated at the first layer of rope on the drum for intermittent periodic duty.
3. The winch is not to be used to lift, support or otherwise transport personnel.
4. A minimum of five (5) wraps of steel wire rope and ten (10) wraps of synthetic rope around the drum is necessary to support the rated load.
5. Keep clear of winch, rope, hook, and fairlead while operating.
6. Rope can break without warning. Always keep a safe distance from the winch and rope while under a load.
7. Failure to adequately align, support, or attach the winch to a suitable mounting base could result in a loss of efficiency of performance or damage to the winch, rope and mounting platform.
8. The winch can generate a huge amount of tension and force. Be aware of moving parts and keep hands clear of the winch drum, as well as where the rope feeds through the fairlead.
9. A fully charged battery and good electrical connections are essential for correct operation of your winch. A 12V 650CCA (cold cranking amps) battery is the minimum recommendation.



### **Safety**

- Before use, ensure that you are familiar with all winching operations (winch speeds & direction).
- In some cases, the operator of a winch may be required to have Qualifications according to applicable laws and ordinances.
- Check all safety and environmental conditions prior to and during use.
- Only use correctly rated rope. Inspect for damage and/or defects before use.
- Do not use an unsuitable hook or snatch block for rope.
- The operator must remain with the winch during operation.
- The winch duty rating is S3 (intermittent-periodic). See page 20.
- Do not use the winch as a lifting device or a hoist for vertical lifting and moving people.
- Ensure that the winch is connected to the correct voltage (12VDC only).
- Do not exceed the maximum line pull ratings shown in this manual. Shock loads must not exceed these ratings.



- Pull from an angle below 15° in the horizontal plane to straighten up the vehicle or load.
- Always use appropriate gloves when handling the winch rope.
- When winching, always use a recovery damper. Place over the rope in the middle third of its length.
- A rope should be replaced if it shows signs of excessive wear, broken strands, corrosion for wire rope and excessive abrasion or fused and melted fibre for synthetic rope or any other defects.
- If the winch fails to pull a load under normal conditions, manually stop the operation, otherwise motor damage may occur.
- Check that the clutch handle is in the "Engaged" position during and after use.
- Disconnect the wired remote control from the winch when not in use and store in a safe, dry place.
- Do not wrap the rope around the load and back onto itself. Always use a tree trunk or winch extension strap.
- Keep hands and clothing clear of the winch, rope, and fairlead opening.
- Never unplug the remote control when winching a load.
- To avoid insufficient power when winching a load, the vehicle should be running and in neutral.
- Keep the remote control clear of the rope at all times.
- When the winch is not in use - keep the winch isolation switch turned off.
- If noise or vibration occurs when operating, stop the winch immediately. If there are any technical concerns speak to your place of purchase or authorized dealer.
- The rope must be wound in an under-wound orientation only to ensure correct brake operation.
- Always inspect the hook, latch and pin prior to use. Do not use if there are any signs of excess distortion or bending.
- Ensure the pin of the hook is secured using a correctly installed split/cotter pin.

#### WRONG FITMENT

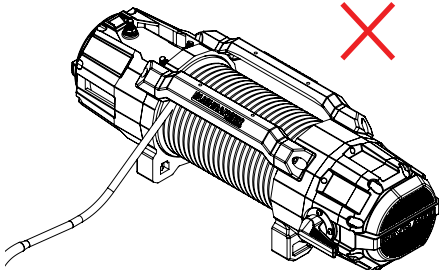

**Overwound**

#### CORRECT FITMENT

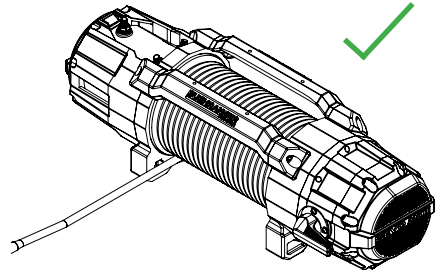

**Underwound**

# Bushranger REVO MKII 10,000LB

## SPECIFICATIONS:

<b>MODEL</b>	RWM100S   RWM100W	
<b>DIMENSIONS</b>	582mm(L) x 194mm (W) x 185mm (H)	
<b>WEIGHT (FITTED)</b>	32.7kg   44.2kg	
<b>RATED LINE PULL (1ST LAYER)</b>	10,000lbs (4,536kg)	
<b>MOTOR</b>	3.9kW (5.2 HP)	
<b>REMOTE CONTROL</b>	Dual Connection Remote Wireless - 30m range / Wired - 5m Lead	Wired - 5m Lead
<b>ELECTRICAL CONTACTOR</b>	Albright DC88P Contactor	
<b>GEARBOX</b>	171:1 - 2 Stage Planetary & 2 Stage Spur gear	
<b>BRAKE</b>	Gearbox mounted 100% load holding proportional friction brake	
<b>CLUTCH</b>	Rotating Ring Gear, 90° Turn handle (no lift)	
<b>ROPE</b>	Grey 10mm diameter x 28m Synthetic Rope with Protective Sleeve	9.2mm Diameter x 28m Wire Rope
<b>FAIRLEAD</b>	Two Position, Aircraft Grade Aluminium Hawse fairlead	Stainless Steel 304 Roller Fairlead
<b>FINISH</b>	Electrophorus Pretreated Black Satin Powder Coated Finish	
<b>WATERPROOF RATINGS</b>	IP68 Winch Motor and Gearbox	
<b>WARRANTY</b>	Limited Lifetime Warranty (7 Year Warranty on Electrical Components)	
<b>CERTIFICATIONS</b>	CE	

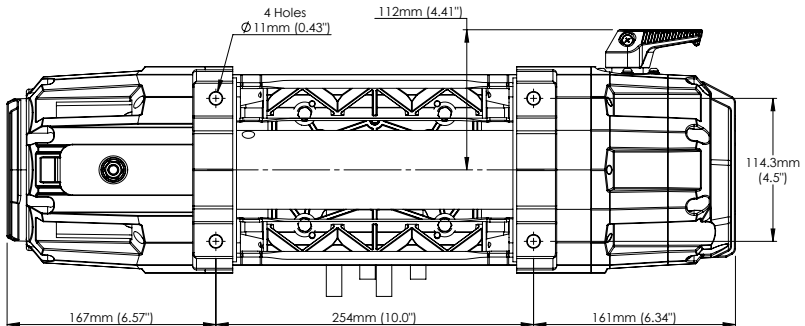

## Performance - 1st layer of drum (10,000lb REVO MKII)

LINE PULL		REVO MKII LINE SPEED		MOTOR CURRENT
lbs	kgs	ft/min	m/min	Amps
0	0	49.2	15.0	45
4000	1814	9.8	3.0	201
6000	2722	7.2	2.2	260
8000	3629	5.2	1.6	322
10,000	4536	3.6	1.1	380

## Performance - Pull by layer

SYNTHETIC				
Layer	kgs	lbs	Total rope on drum (m)	Total rope on drum (ft)
1	4536	10,000	5.1	16.7
2	3560	7849	11.4	37.4
3	2930	6460	18.6	61.0
4	2490	5489	26.7	87.6
5	2164	4771	28.0	92.0

WIRE				
Layer	kgs	lbs	Total rope on drum (m)	Total rope on drum (ft)
1	4536	10,000	5.5	18
2	3560	7849	12.2	40
3	2930	6460	19.8	65
4	2490	5489	28.0	92

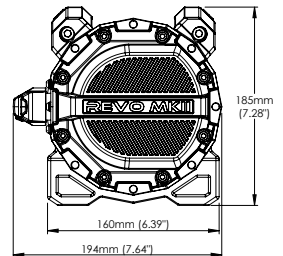
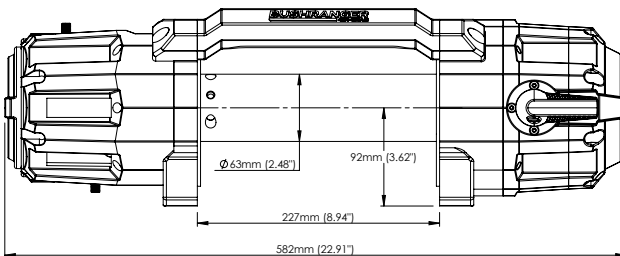

# Bushranger REVO MKII 12,000LB

## SPECIFICATIONS:

<b>MODEL</b>	RWM120S   RWM120W	
<b>DIMENSIONS</b>	600mm(L) x 194mm (W) x 185mm (H)	
<b>WEIGHT (FITTED)</b>	33.9kg   46.7kg	
<b>RATED LINE PULL (1ST LAYER)</b>	12,000lbs (5,443kg)	
<b>MOTOR</b>	4.6kW (6.2 HP)	
<b>REMOTE CONTROL</b>	Dual Connection Remote Wireless - 30m range / Wired - 5m Lead	Wired - 5m Lead
<b>ELECTRICAL CONTACTOR</b>	Albright DC88P Contactor	
<b>GEARBOX</b>	171:1 - 2 Stage Planetary & 2 Stage Spur gear	
<b>BRAKE</b>	Gearbox mounted 100% load holding proportional friction brake	
<b>CLUTCH</b>	Rotating Ring Gear, 90° Turn handle (no lift)	
<b>ROPE</b>	Grey 11mm diameter x 24m Synthetic Rope with Protective Sleeve	10.3mm Diameter x 25m Wire Rope
<b>FAIRLEAD</b>	Two Position, Aircraft Grade Aluminium Hawse fairlead	Stainless Steel 304 Roller Fairlead
<b>FINISH</b>	Electrophorus Pretreated Black Satin Powder Coated Finish	
<b>WATERPROOF RATINGS</b>	IP68 Winch Motor and Gearbox	
<b>WARRANTY</b>	Limited Lifetime Warranty (7 Year Warranty on Electrical Components)	
<b>CERTIFICATIONS</b>	CE	

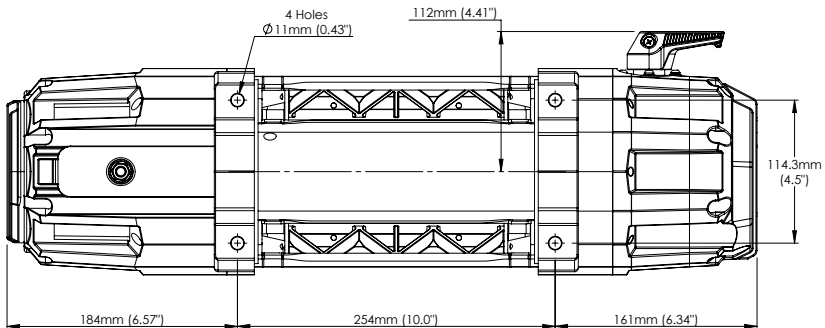

## Performance - 1st layer of drum (12,000lb REVO MKII)

LINE PULL		REVO MKII LINE SPEED		MOTOR CURRENT
lbs	kgs	ft/min	m/min	Amps
0	0	65.6	20.0	55
4000	1816	10.5	3.2	210
6000	2722	7.5	2.3	270
8000	3629	5.9	1.8	325
10,000	4536	3.9	1.2	390
12,000	5443	3.3	1.0	420

## Performance - Pull by layer

SYNTHETIC				
Layer	kgs	lbs	Total rope on drum (m)	Total rope on drum (ft)
1	5443	12,000	4.2	13.7
2	4196	9250	9.3	30.5
3	3413	7525	14.5	47.5
4	2877	6343	20.0	65.6
5	2486	5481	24.1	79.0

WIRE				
Layer	kgs	lbs	Total rope on drum (m)	Total rope on drum (ft)
1	5443	12,000	4.7	15.4
2	4196	9250	10.8	35.4
3	3413	7525	17.2	56.4
4	2877	6343	25.0	82.0

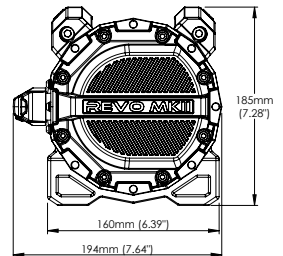
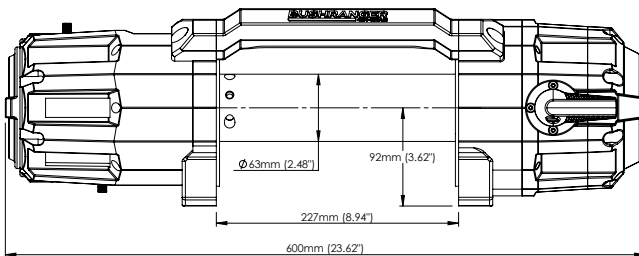

# Installation

It is highly recommended that installation is performed by an authorised technician.

## Winch mounting

- It is very important that the winch is mounted on a flat and hard surface/mounting channel or in a suitably rated winch-compatible bull bar to ensure the motor, drum and gearbox housing are aligned correctly.
- The fairlead is not designed to mount to the winch directly.
- The rope must be wound in an under-wound orientation only.

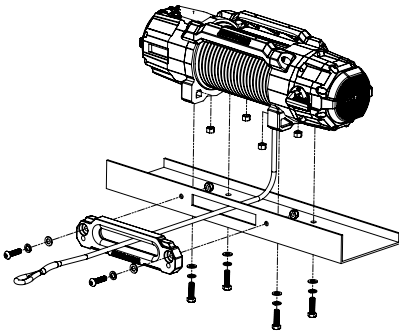

Foot Down Installation

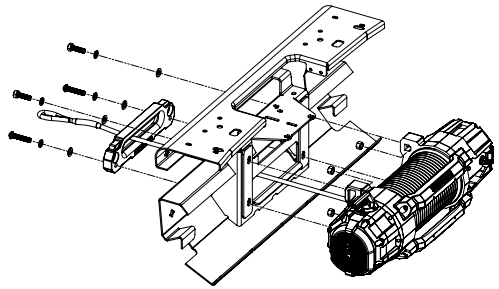

Foot Forward Installation

The winch is provided with a range of bolts to suit different mounting options:

- 4 x M10x35mm Hex Head bolts (for foot down installation)
- 2 x M10x50mm Button Head Bolts (for mounting Hawse Fairlead in foot forward mounting – REVO MKII 10S & 12S only)
- 2 x M10x45mm Button Head Bolts (for mounting Roller Fairlead in foot forward mounting – REVO MKII 10W & 12W only)
- 2 x M10x40mm Button Head Bolts (for mounting Hawse & Roller Fairlead in foot down mounting)
- 6 x M10 Spring Washers
- 6 x M10 Flat Washers
- 4 x M10 Hex Nuts
- 2 x M10 Nyloc Nuts

Note: Four (4) M10 x 1.50 pitch 10.9 grade high tensile steel bolts (supplied) must be used in order to sustain the loads imposed on the winch mounting.

Torque Settings (Maximum)	
M10 x 1.5– 10.9 Grade	44 N.m

## Control Box mounting

The REVO MKII Control Box is designed with multiple mounting options to suit a wide variety of vehicles and bullbars. Provided with a range of fasteners to suit different mounting options including:

Tie bar mounting (shown in **green**), directly to the winch;

- 4 x M5 x 20mm Socket Head bolts
- 4 x M5 Flat Washers
- 4 x M5 Spring Washers

Bullbar or flat surface remote mounting (shown in **red**):

- 4 x M6 x 16mm Hex Head bolts
- 4 x M6 Large Diameter Flat Washers
- 4 x M6 Spring Washers

Always ensure that the electrical cables between the control box and winch are well secured to the vehicle or winch.

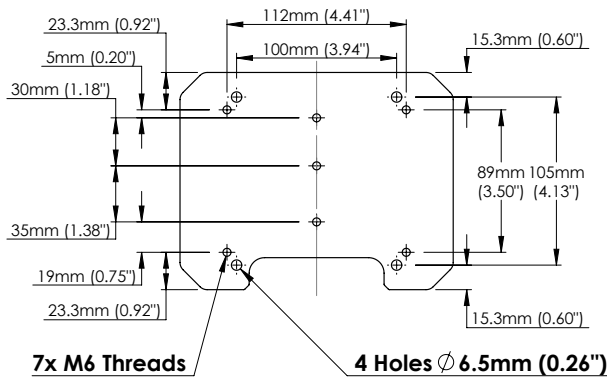
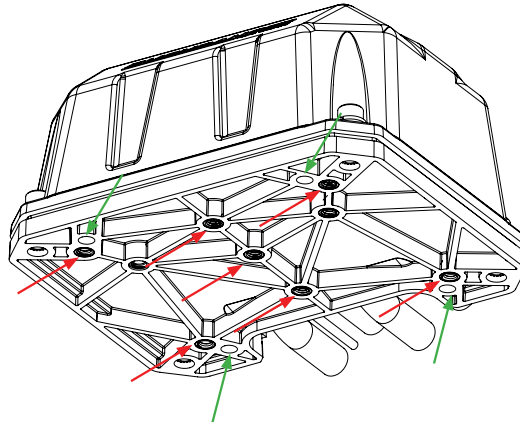

## Control Box Base - Mounting Dimensions



### Mounting Directly to the tie bar

- The control box may be fitted directly to the winch tie bars.
- Partially remove the plastic control box cover by undoing the 4x M6 bolts and moving it aside. Then align the 4x 6.5mm diameter holes in the control box base to the 4x M5 threaded holes in the winch tie bars. Use 4x M5 bolts, flat washers and spring washers to secure the control box to the winch, then reinstall the plastic control box cover.

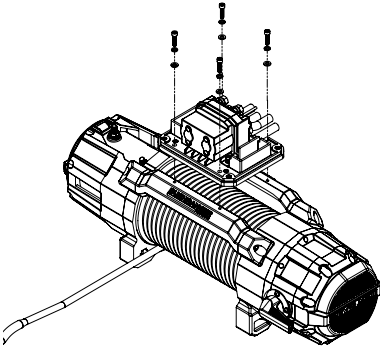

**Use M5 fasteners to secure control box base to winch tie bars**

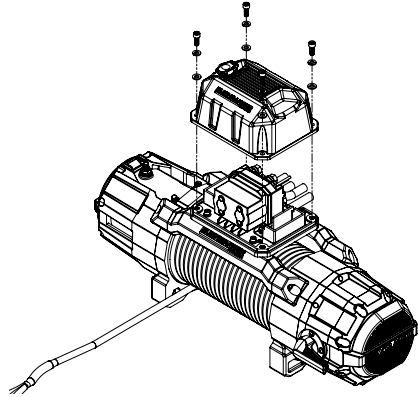

**Reinstall M6 fasteners and Plastic Cover**

### Mounting to a Bullbar / Flat Surface

- The control box incorporates 7x M6 metal threads which are moulded into the control box base. These are strategically located to align with popular bullbar mounting holes.
- Choose the most appropriate threads to align with the holes in the mounting surface, and secure the control box using the M6 fasteners provided.
- A minimum of 2x fasteners should be used, but it is recommended to use 3 or 4 to ensure a solid, robust mounting outcome is achieved.

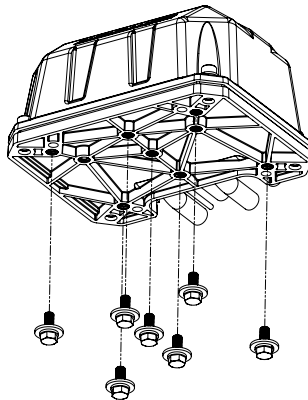

## Gearbox Rotation

The gearbox is preset at position 'A' which suits the majority of vehicle fitments, however the gearbox can be rotated in 22.5° increments to allow for the clutch handle to be orientated to best suit the installation requirements.

1. Loosen and partially remove the 8 x bolts (see important note and red arrows below) that secure the two gearbox sections to the winch. **DO NOT** remove the gearbox sections from the winch.
2. Rotate the two gearbox sections and bolts simultaneously (all moving parts highlighted in grey) to achieve the target angle as highlighted below. Ensure the gearbox seal resets in the correct position.
3. Reinstall and tighten all bolts to Max 19Nm with torque wrench.

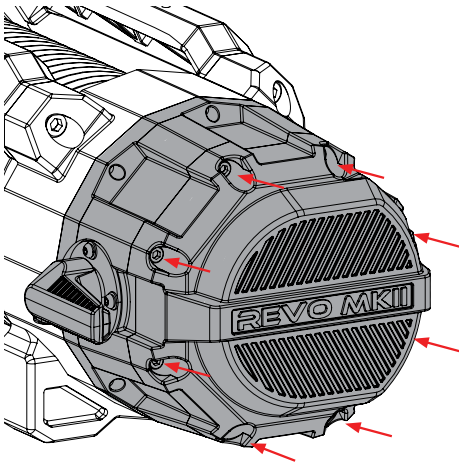

**STEP 1**

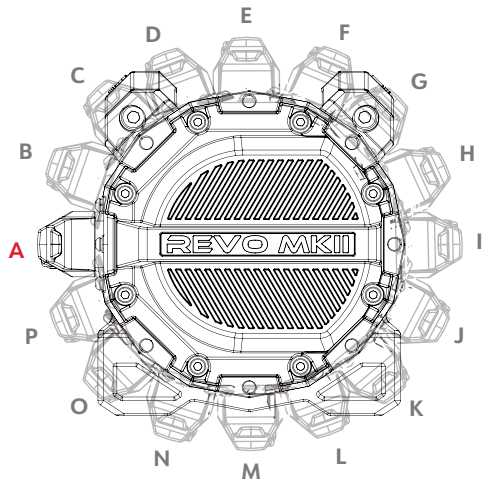

**STEP 2**

### Important note:

**DO NOT USE** a Power Tool such as an impact driver. This may lead to the stripping of bolt threads or heads of bolts.

## Motor Rotation

The motor can be rotated and positioned in 3 orientations to best suit the installation requirements:

- Motor poles orientated up – as supplied in the box
  - Motor poles rotated forward 90°
  - Motor poles rotated rearward 90°
1. Loosen and remove the 6 x bolts that secure the motor cover to the drum support. (shown in **red**). Remove the motor cover from the winch.
  2. Loosen and partially remove the 2 x bolts that secure the motor to the drum support. (shown in **green**)
  3. Rotate the motor to the desired position, ensuring the motor seal and locating pin reseats into the correct position on the drum support. Reinstall the motor bolts and tighten to 10Nm with a torque wrench.
  4. Reinstall the motor cover and tighten the 6x bolts to 1.5Nm with a torque wrench.

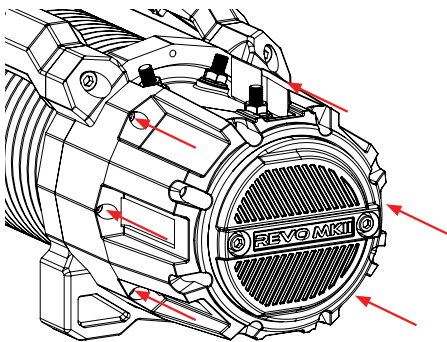

**STEP 1**

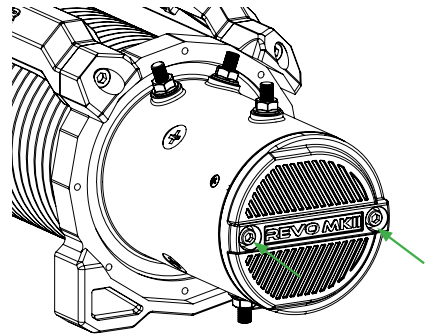

**STEP 2**

### Important Note:

**DO NOT USE** a Power Tool such as an impact driver. This may lead to the stripping of bolt threads or heads of bolts.

## Battery Recommendations

A fully charged battery and good connections are essential for the proper operation of your winch. **The minimum requirement for a 12 Volt DC battery is 650 cold cranking amps.**

- Do not lean over batteries while making connections.
- The earth wire should be disconnected during installation.

# Wiring Installation

The winch is supplied with a universal fitment isolation switch which must be installed to allow for complete isolation of the winch from the vehicle battery.

**IMPORTANT: Always turn the isolation switch off when the winch is not in use.**

Installation Steps:

- Find a suitable location close to the vehicle's battery to mount the isolation switch utilising the supplied universal bracket or a custom bracket where required. Note: Remove the isolation switch key during installation of the wiring.
- Route the long positive 2AWG wire (red) from the control box to one of the isolation switch terminals. Tighten the isolation switch terminal to a maximum of 10Nm torque.
- Connect the 3x 2AWG wires (black) from the control box to the winch motor terminals (A, F1, F2), matching the colours on the ends of the wires with the colours on the motor terminals. Refer to Nut Fastening instructions on next page, then slide the protective boots over the terminals.
- Connect the long negative 2AWG wire (black) from the motor ground terminal to the negative battery terminal. Also connect the thin black wire from the control box to the motor ground terminal. Refer to Nut Fastening instructions on next page, then slide the protective boot over the terminal.
- Route the short positive 2AWG wire (red) from the positive battery terminal to the remaining isolation switch terminal. Tighten the isolation switch terminal to a maximum of 10Nm torque.

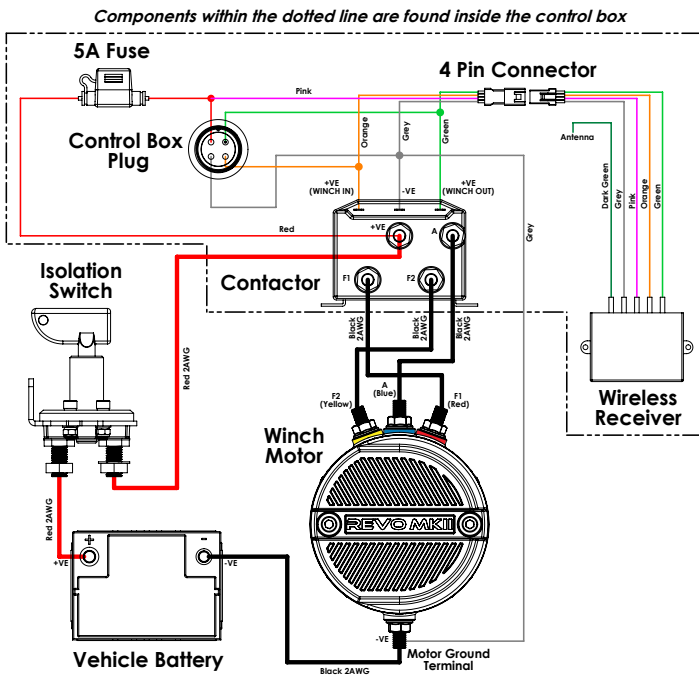

## Nut fastening for motor pole terminals

The nuts on the motor should be fastened to the specified torque as outlined in the diagram below. Attempting to fasten the top nut without locking the bottom nut could result in damage to the studs or internal windings of the motor. Do not tighten the top nut without locking the bottom nut.

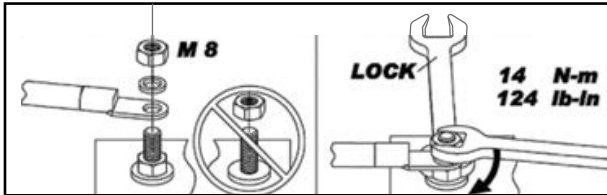

## Operational Checklist (Prior to Use)

---

It is important to check and prepare the winch after installation, to ensure everything is correctly setup and ready for use.

### Installation Checklist

- Check the operation of the isolation switch.
- Check the hand controller connections are functioning.
  - Wired Connection:** Connect the 5m lead from the hand controller plug to the control plug (see page 22).
  - Wireless Connection:** Hold wireless button and await the green light (see page 22)
- Test the Clutch Handle freespool mechanism. (See page 21)
- Rope Preparation (Wire & Synthetic)**

Prior to using the rope for the first time, it must be tensioned onto the drum under load to ensure a tight and uniform wrap is achieved. A rope that is not tensioned and wound tightly and evenly prior to use can be permanently damaged since the outer layers of rope can draw down into the inner layers leading to binding, pinching or wedging between layers.

One method for tensioning the rope onto the drum is to use the weight of the vehicle on a slight incline to pull on the rope while spooling in. This can be achieved by following the steps outlined in the following section "Winch Operation" (Page 21-27). Prior to spooling in under this load, ensure the rope is pulled out to leave the minimum amount of wraps on the drum (5 wraps for wire rope and 10 wraps for synthetic rope).

Note: There is a red indicator mark on the rope identifying the maximum available length.
- Place the hand controller, 5m lead and these instructions in the glove box (or alternate location in the vehicle cab) together.

# Optional Winch Products/Accessories

It is recommended to use Bushranger winch and recovery products that have been designed and tested alongside this winch.

## Tree Trunk Protector Strap

RTS11

A tree trunk protector strap is useful for connecting a rope to almost any anchor point but is primarily designed to prevent a tree from ring barking. The tree trunk protector should be wrapped around the chosen tree or anchor point as low to the ground as possible and the two ends brought together and joined with a bow shackle. The bow shackle then becomes the recovery point to where the rope or extension strap is joined.

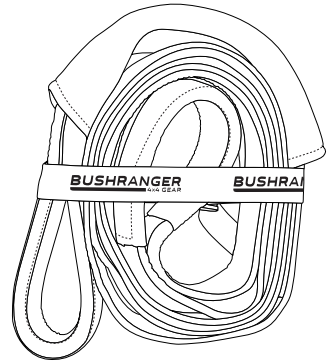

## Snatch Block

RBS11

A snatch block is an important aid to successful winching and can be used to increase the pulling power (or mechanical advantage) of a winch, or change the direction of a pull.

Where a double line pull is used (i.e. where a snatch block is used at the load or anchor point and the winch rope is connected back to the vehicle), twice the pull force is applied but the speed of recovery is halved.

One snatch block can be used in an indirect pull where the vehicle is limited due to unsuitable ground or obstruction. In this instance, the pull on the load is the actual line pull of the winch.

If more than one snatch block is used, they must be located at least 1m (40") apart.

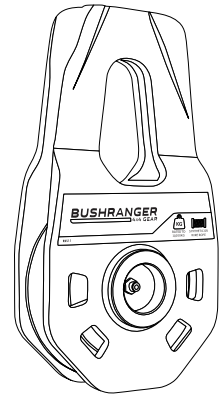

## Recovery Damper

61X05

A recovery damper is a safety device designed to help eliminate the possibility of injury or property damage in the event of a rope failure. Placed in the middle third of a live rope, in the event of the rope breaking, the damper can help absorb the energy in the rope and reduce the likelihood of injury or damage.



## Bow Shackles

58X01K | 58X02K

Only bow shackles that are load rated should be used for vehicle recovery. Load ratings are visible on the shackle and will be in the form of WLL (working load limit) or SWL (safe working load). The shackles, or any other recovery equipment, used should be sized correctly for the winching task.

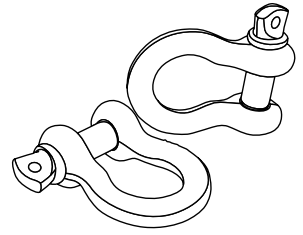

## Winch Extension Strap

RSW05

Used when your rope isn't long enough to reach the recovery anchor point, extension straps are made from polyester webbing and come in various lengths and load ratings to suit varying recovery situations.

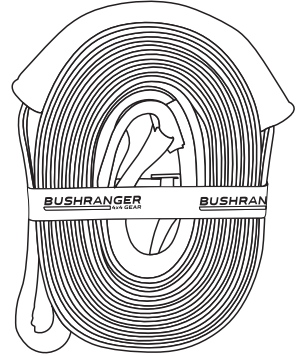

## Bridal/Equaliser Strap

Designed to spread the load of the recovery across two points on the vehicle requiring assistance. Can be used in both Snatch Strap or Winching recoveries.

# Winching Principles

**NOTE:** Bushranger 4X4 Gear recommend that prior to using this recovery equipment, users should undertake formal training from an accredited industry body in winch use and vehicle recovery.

## Calculating Fleet Angle

To obtain the best rope service, the direction of pull should be on a horizontal plane within  $\pm 15$  degrees and perpendicular to the centreline of the winch drum within  $\pm 15$  degrees. If the fleet angle is larger than the recommended angles, incorrect spooling may occur, resulting in the rope loading onto one side of the rope drum and possible damage to the rope or winch.

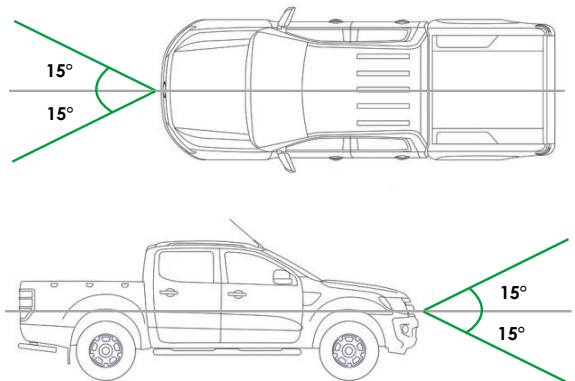



## Required Pulling Force

Your winch must be powerful enough to overcome the resistance caused by an obstacle, such as moving water, mud, snow, sand or on a steep hill, as well as pulling the vehicle's full weight.

As a general guide, you need a winch with a maximum line pull at least 1.5 times greater than the gross vehicle weight.

There are three factors listed that have influence on the line pull effect required to recover the vehicle. The values and calculations in this section are approximate and are for reference only.

- a) Gross vehicle mass (GVM)
- b) Type of surface to be traversed
- c) Gradient to overcome

In recovery and loading, where the winch is used to pull something, the required pulling force (RPF) can be calculated according to the formula:

$$RPF = (Wt \times S) + (Wt \times G)$$

Where:

- Wt = the gross vehicle mass (GVM)
- S = the type of surface to be traversed
- G = the gradient to overcome

Surface Type	Surface Drag (S)
Metal	0.15
Sand	0.18
Gravel	0.20
Soft Sand	0.22
Mud	0.32
Marsh	0.52
Clay	0.52

Gradient	Angle (θ)	Gradient (G)
5%	3°	0.06
10%	6°	0.11
20%	11°	0.2
30%	17°	0.3
50%	26°	0.44
70%	35°	0.58
100%	45°	0.71

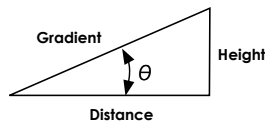

For example, if a vehicle weighing 3,000kg is winched up an incline of 100% on a marshy surface, the above formula would be used as follows:

$$\begin{aligned}
 \text{Where} \quad Wt: & 3,000\text{kg}, \quad S: 0.52 \quad G: 0.71 \\
 RPF &= (Wt \times S) + (Wt \times G) \\
 &= (3,000\text{kg} \times 0.52) + (3,000\text{kg} \times 0.71) \\
 &= 1,560\text{kg} + 2,130\text{kg} \\
 &= 3,690\text{kg of effect required to recover the vehicle.}
 \end{aligned}$$

Note: A gradient of 10% is a rise of one metre in ten metres (Height/Distance).

## Duty Cycle Ratings

Duty cycle ratings usually specify continuous, intermittent, or special duty (typically expressed in minutes). The IEC (International Electrotechnical Commission) lists the following ratings:

- S1 - Continuous duty  
The motor works at a constant load for enough time to reach temperature equilibrium.
- S2 - Short-time duty  
The motor works at a constant load, but not long enough to reach temperature equilibrium, and the rest periods are long enough for the motor to reach ambient temperature.
- S3 - Intermittent periodic duty  
Sequential, identical run and rest cycles with constant load. Temperature equilibrium is never reached. Starting current has little effect on temperature rise.

**All automotive winches are rated at S3 intermittent periodic duty.**

## Load Rating

Load and speed vary according to much rope is on the drum. The first layer of rope on the drum delivers the slowest speed and the maximum load. A full drum delivers the maximum speed and the minimum load. For this reason, automotive winches are rated at their first layer capacities

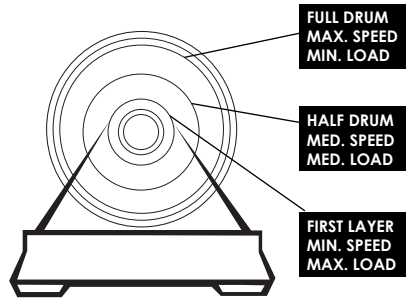

# Winch Operation

---

## Important notes before operating the winch

### Clutch Operation

The clutch handle either "Engages" the winch for operation or "Disengages" the winch for free spooling of the rope. The clutch must always be "Engaged" before operating the winch under load.

- 1) To disengage, turn the clutch handle 90° in a clockwise direction to the "Disengaged" position. The rope can now free spool off the drum.
- 2) To engage, turn the clutch handle 90° in a counter-clockwise direction to the "Engaged" position.
- 3) If the clutch handle cannot be properly locked in the "Engaged" position, rotate the drum by pulling on the rope, to allow the clutch mechanism to engage the gear train.
- 4) Wear appropriate gloves and use a pull strap when guiding the rope off the drum.
- 5) Never disengage the clutch while the rope is under load. The clutch handle must be returned to the "Engaged" position before winching.

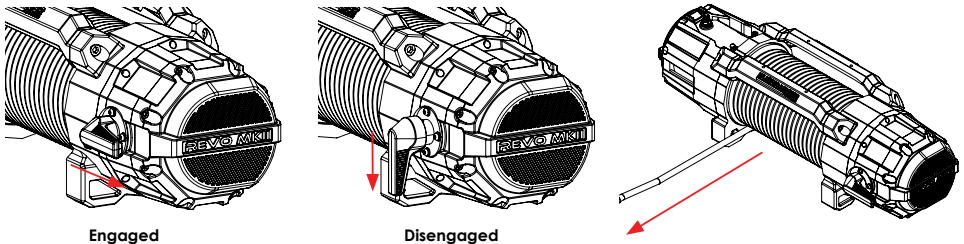

### Powering Out (No Load)

The unique Proportional Brake in the Bushranger REVO MKII winch allows for effortless powering OUT under NO LOAD, with no concern for damage occurring to the brake or motor. In most circumstances powering out the rope may be quicker and easier than free spooling by hand. As the rope is powered out, pay careful attention to guide it off the drum under a small amount of hand tension to avoid the rope becoming "over wound" on the drum or bunching up.

### Powering Out (Under Load)

It is not recommended to power OUT the winch rope UNDER LOAD for longer than 30 seconds. Exceeding this time will cause high amounts of wear to the brake.

## Cable-in/Cable-out Operation

The hand controller is paired to the winch as standard and is ready to operate in wireless mode on install/oncepowered on.

## **Wireless Mode**

### Activating Wireless Mode

Press and hold the Wireless Power Button  for 3 seconds to activate the Wireless Control.

The WIRELESS light will illuminate to indicate you are in WIRELESS mode. To turn off, press and hold the Wireless Power Button  for 3 seconds until the WIRELESS light turns off. The controller is also equipped with an automatic power off function. If the hand controller is not operated for 2 minutes it will turn off automatically to conserve battery power.

**To “Winch - Out”,** Press and hold the “OUT” Button

**To “Winch - In”,** Press and hold the “IN” Button

**To stop winching,** release the button.

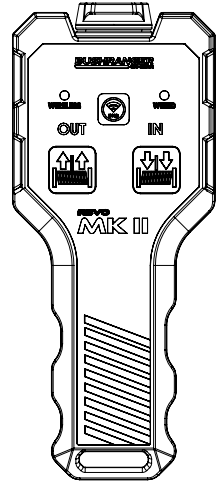

### Pairing of new Hand Controller

In the case a replacement winch hand controller is required;

1. Ensure the winch and wireless receiver power is turned OFF via the isolation switch.
2. Turn on the hand controller to Wireless Mode by pressing the  button for 3 seconds until the Wireless Light flashes green.
3. Press and hold the IN and OUT buttons simultaneously. Both the Wireless and Wired lights will go solid. Continue to HOLD as both lights begin to flash slowly – Do not release.
4. Whilst still holding the IN and OUT buttons – Turn ON power to the winch and wireless receiver via the isolation switch.
5. After a further 2 seconds of holding, release the IN and OUT buttons. The Wireless Light will return to normal flashing and the pairing is complete.

### Changing battery in the Hand controller

To replace the battery, remove the screws in the rear panel of the hand controller. Replace the A23 battery and reassemble the hand controller. When reassembling the hand controller, ensure that the rubber seal is aligned and not pinched.

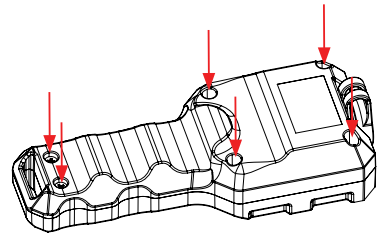

## **Wired Mode**

The wireless hand controller can also be used in wired mode. Connect the winch hand controller cable to the control plug and the hand controller. When the cable is plugged in, the “Wired” light will illuminate RED.

## Basic Winching Process

### 1) Establish an Anchor Point

When choosing an anchor point, select a firm point such as a tree, stump or rocks. **DO NOT WRAP THE ROPE AROUND THE ANCHOR POINT AND BACK ONTO ITSELF.** Always use a tree trunk protector strap to prevent ring barking the tree and damage to the rope. If using a winch to retrieve another stranded vehicle, the rescue vehicle is considered the anchor point and should be made secure. The anchor point must be strong enough to hold the gross weight of the vehicle and be positioned to keep the fleet angle between the centre of the anchor point and the wire rope maintained at less than 15°.

### 2) Turn on Power to the Winch

Turn power ON to the winch via the red isolation switch, located close to your vehicles battery. Insert the red key and turn 90° to enable the electrical connection.

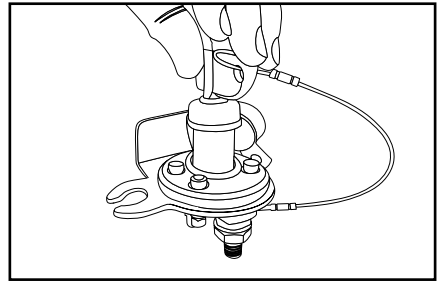

### 3) Turn on the Hand Controller

Connect the hand controller either wirelessly (see page 22) or via the control plug lead. Always disconnect the hand controller when not in use.

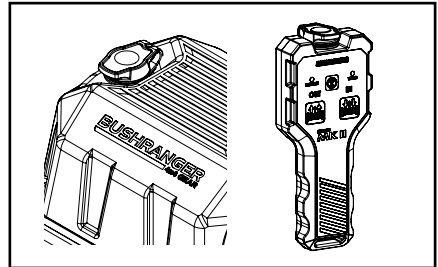

### 4) Disengage the Clutch (for freespool operation)

Turn the clutch handle in a clockwise direction to the "Disengaged" position. The rope is now free to be unwound from the drum by hand. Never disengage the clutch while the rope is under load. Do not disengage the clutch if powering out in Step 3.

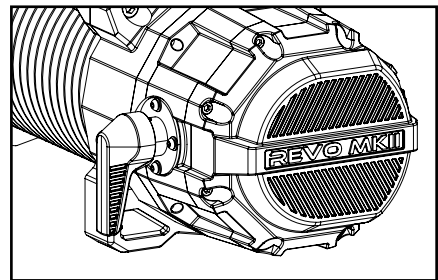

**Please note:** The Bushranger REVO MKII winch can be powered out under no load, and in most situations it may be faster. Pay careful attention not to allow the rope to become "over wound" on the drum when powering out.

### 5) Pull or Power Out the Rope to the Anchor Point

Wear appropriate gloves when handling rope. Hold the Pull Strap and pull or power out enough rope to reach the anchor point. Keep tension on the rope when unspooling.

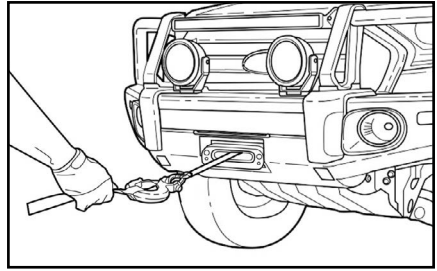

### 6) Engage the Clutch (if freespoiled)

To engage, turn clutch handle in a counter-clockwise direction to the "Engaged" position. Never engage the clutch while the drum is rotating. The drum may need to be rotated slightly by hand to ensure proper engagement.

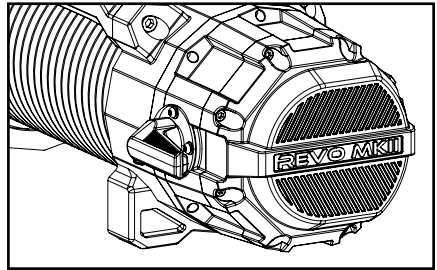

### 7) Check the Rope

Before winching, ensure the rope is wound on the drum evenly. If unevenly wound, there is a possibility of damaging the rope when under load. Visually check rope for any signs of damage.

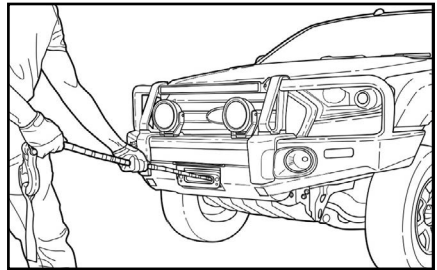

### 8) Attach the Shackle and Hook

Use a shackle to lock both ends of the tree trunk protector and then attach to the hook.

**Please note:** The winch line is now live. Do not step over or cross the rope.

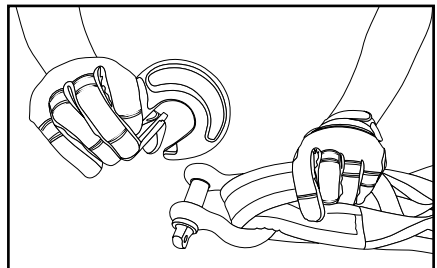

### 9) Use a Recovery Damper

Lay a recovery damper or heavy blanket over the rope in the middle third of its length. If a rope failure occurs, the damper can prevent the rope from whipping.

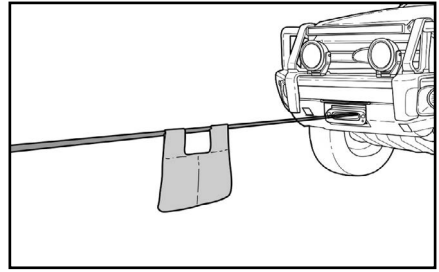

### 10) Prepare the Vehicle

The recovery vehicle's engine should be running to provide maximum power to the winch. The transmission should be set in neutral and the hand brake applied to prevent the vehicle from moving.

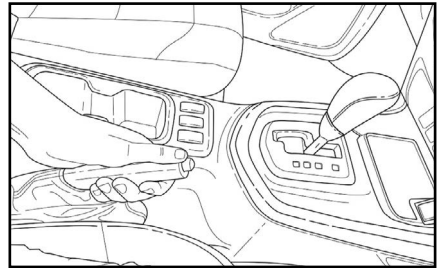

### 11) Begin Winching

Keep tension on the rope to ensure it winds onto the drum tightly and evenly and does not sink into the lower layers. Release Hand brake and continue pulling until the vehicle is recovered.

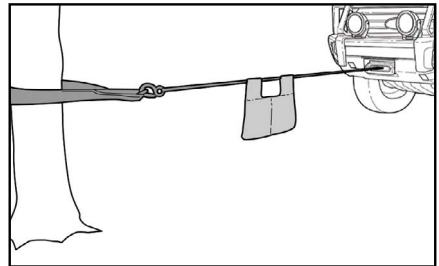

### 12) After Winching

Once the vehicle is recovered and safely secured, wind the remaining rope back onto the drum tightly and evenly and secure the hook firmly. Check rope/parts for wear or damage.

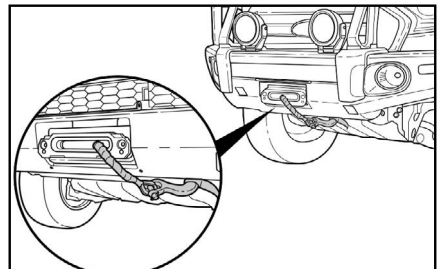



### 13) Disconnect the Hand Controller

Disconnect the wireless mode (See page 22), or unplug the hand controller cable at both ends. Store the hand controller in a safe, dry and easily accessible place.

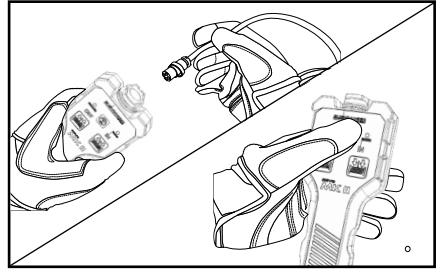

### 14) Turn off Power to the winch

Turn power OFF to the winch via the red isolation switch, located close to your vehicles battery.

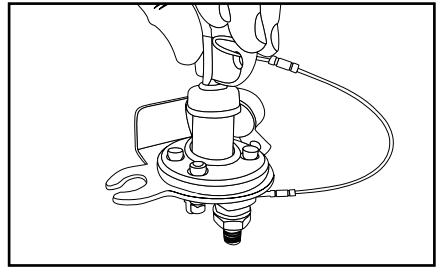

## Precautions Whilst Winching

- Make sure the rope is wound onto the drum tightly and evenly. Allowing the rope to become loosely wound can result in binding, pinching and wedging between layers, ultimately damaging the rope, shortening its life and increasing the risk of injury and failure under load.
- Always keep clear of the winch, rope, hook and fairlead while winching.

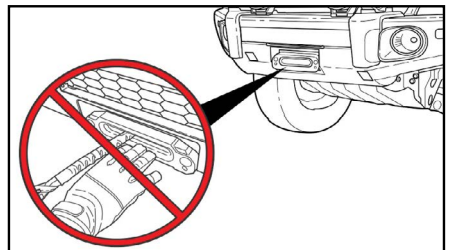

- Keep winching area clear. Do not allow people to remain in the area while winching. Never step over a live rope whilst under load.

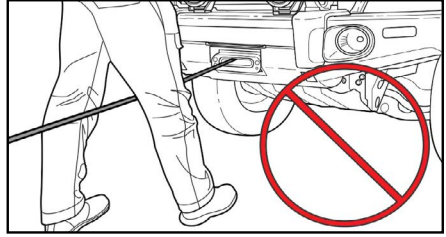

- Never guide a rope onto the drum with your hand. Use the supplied Pull Strap.

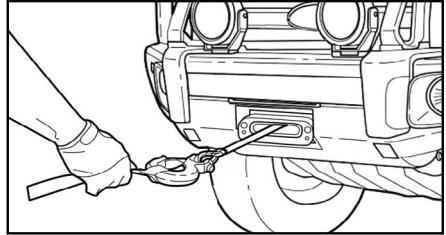

- Avoid the hand controller cable from coming in to contact with the winch, rope or fairlead, as damage to the cable may result.

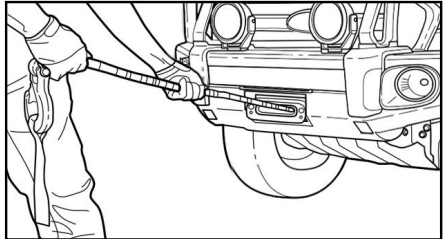

- A winching operation requires extra consumption of battery power, so always maintain your battery and ensure it is in good condition.

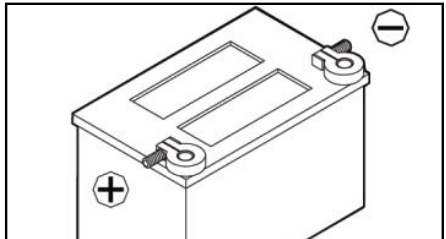

# Maintenance

---

## Cleaning

Only use low pressure water to clean the synthetic rope. Do not use any chemicals. We recommend using low pressure water and a soapy sponge to clean the winch. If high pressure water is used, do not direct it at the drum area or the clutch handle. Using high pressure water in these areas can force water past seals and lead to internal water build up which can damage the winch.

## Tips for Prolonging the Life of Synthetic Rope

1. Periodically check the rope for damage or wear. Frayed, kinked or damaged winch rope must be replaced immediately.
2. When the rope is used for the first time, the outer filaments may fray. This is a result of the outer filaments breaking. The roughened surface will actually protect the inner fibres.
3. Inspect both inner and outer fibres. Open the strands and look for powdered fibre. This is a sign of internal wear.
4. Protect your rope from rubbing against sharp or abrasive objects.
5. Keep your synthetic rope clean and dry. To clean it after use in muddy conditions, spool out the rope, rinse it with fresh water and let it dry completely before re spooling.
6. All synthetic ropes are affected by UV rays, chemicals, abrasion and heat. Once the synthetic rope has begun to deteriorate the breaking strength is compromised. It is recommended that synthetic rope is replaced every 12 months once fitted or UV exposed.

## Servicing

Servicing and repairs should only be carried out by an authorised dealer. Unauthorised repairs or servicing will void warranty. The maintenance scheduled should be followed to ensure reliable operation for the life of the winch. The winch should be used regularly to ensure components are kept in good working order. At a minimum, it is recommended that the rope is powered out and then powered back in on a monthly basis by following the correct winching procedures (Page 23-27). The drum support seals are a wearing item and are critical to retaining the sealed design of the winch. These should be inspected and greased or replaced as required depending on the frequency of use and the operational environment.

All moving parts in the winch are permanently lubricated at the time of assembly. Under normal conditions, factory lubrication will suffice. If re-lubrication of the gear box is necessary after repair or disassembly, use Shell EP2 or equivalent grease. The clutch handle can be lubricated regularly with light oil.

## Maintenance Schedule

1. Ensure that a responsible person carries out all inspections as per schedule.
2. Inspections are divided into Daily, Monthly and Three Months.

Classification of check			Item	Checking Method	Checking Reference	
Daily	Periodical					
	One month	Three months				
○			Installation	Mounting bolts & alignment	Bolt tension & wear	Existence of abnormalities
○			Remote control	Correct operation	Manual	Reasonable actuation
○			Wire rope	Broken strands	Visual, measuring	Less than 10%
○	○			Decrease in rope diameter	Visual, measuring	7% of nominal diameter max
○				Deforming or corrosion	Visual	Existence of abnormalities
○				Fastening to hook and drum assemblies	Visual	Existence of abnormalities
○			Synthetic rope	Broken strands	Visual, measuring	Two or more adjacent strands are cut
○	○			Decrease in rope diameter	Visual, measuring	25% of nominal diameter max
○				Fused or melted fibres	Visual	Existence of abnormalities
○				Fastening condition of end	Visual	Existence of abnormalities
		○	Clutch assembly	Damaged clutch assembly	Visual evidence of wear	Free of wear or damage
		○	Motor	Staining, damage	Visual evidence of wear	Existence of abnormalities
○			Brake	Ability to hold loads	Visual	Reasonable actuation
		○	Gears	Smooth operation	Visual, auditory	Reasonable actuation
		○	Seals	Damaged or worn seals	Visual evidence of wear	Free of wear or damage

## **Synthetic Rope Replacement | RWRA004/RWMA011**

Always use a replacement rope that is correctly rated for the capacity of the winch. Use the following method to replace the synthetic rope:

1. Disengage the clutch handle.
2. Spool out the entire synthetic rope, loosen the set screw and then remove rope from the drum and replace the hawse fairlead if necessary.
3. If the end of the rope is not shrink wrapped, cut the lateral side of the end of the rope at a 45° angle and apply 2-3 wraps of electrical tape to the end to hold cut strands in place.
4. Thread the rope through the hawse fairlead and under the drum, then insert the rope all the way through the hole in the end of the drum with 15-20cm protruding out.
5. Place the protruding section of rope across the drum and tape the end down to hold it in place. Lightly tighten the set screw to squeeze the rope. Do not over tighten.
6. Fit the clevis hook to the thimble end of the rope and ensure the split/cotter pin is correctly installed to secure the pin.
7. Wind the red section of rope onto the drum tightly and evenly (under hand tension) to have a minimum of ten (10) wraps of wire rope on the drum.
8. Follow the procedure outlined in the previous sections "Rope Preparation" (Page 16) and "Winch Operation" (Page 21-27) to complete the installation of the replacement synthetic rope.
9. A minimum of ten (10) wraps of synthetic rope around the drum is necessary to support the rated load.
10. A red painted section of the rope warns the operator that there is 3 meters of rope left on the drum. Do not wind out past this point.

## **Wire Rope Replacement | RWRA001/RWRA012**

Always use a replacement rope that is correctly rated for the capacity of the winch. Use the following method to replace the wire rope:

1. Disengage the clutch handle.
2. Spool out the entire wire rope, loosen the set screw and then remove the rope from the drum.
3. Feed the replacement wire rope through the roller fairlead opening, pass below the drum, and insert it into the hole on the drum end. Tighten the set screw to secure the wire rope.
4. Fit the clevis hook to the thimble end of the rope and ensure the split/cotter pin is correctly installed to secure the pin.
5. Wind the red section of rope onto the drum tightly and evenly (under hand tension) to have a minimum of five (5) wraps of wire rope on the drum.

6. Follow the procedure outlined in the previous sections "Rope Preparation" (Page 16) and "Winch Operation" (Page 21-27) to complete the installation of the replacement wire rope.
7. A minimum of five (5) wraps of wire rope around the drum is necessary to support the rated load.
8. A red painted section of the rope warns the operator that there is 3 meters of rope left on the drum. Do not wind out past this point.

**TAPE (Black). View from rear of winch.**

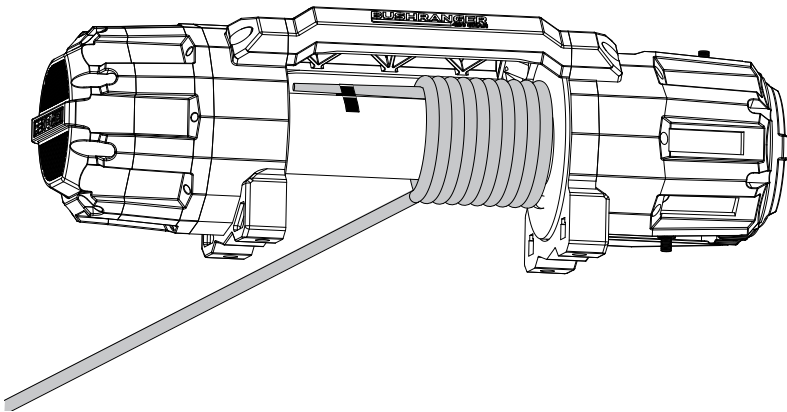
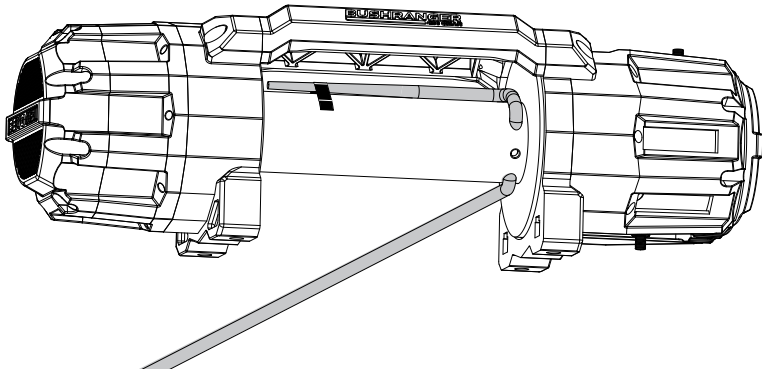

# Troubleshooting

If the winch fails to operate after several attempts, or if there is any fault whilst operating:

Symptom	Possible Cause	Remedy
Winch will not operate	Cut circuit	Check battery lead
	Weak battery	Recharge or replace battery (at least 650CCA)
	Bad connection of wirings	Reconnect tightly
	Damaged contactor	Replace contactor
	Cut circuit on switch	Replace switch
	Damaged motor or worn brushes	Replace motor or brushes
	Faulty motor wirings	Replace wirings
Motor runs in only one direction	Broken wirings or bad connections	Reconnect or replace wirings
	Damaged or stuck contactor	Replace contactor
	Switch inoperative	Replace switch
	Faulty wiring	Replace wiring
Drum will not free spool	Clutch does not disengage	Engage clutch
	Damaged 1st stage shaft	Replace 1st stage shaft
	Damaged brake	Replace brake
	Damaged motor output shaft	Replace motor output shaft
Brake fails to operate	The gear train is mechanically binding up	Check to ensure the winch is mounted on a flat, rigid surface
	Damaged brake	Replace brake
	Damaged gear box	Replace gear box
	Damaged ratchet	Replace ratchet components
Braking distance is too long	Worn brake	Replace brake
Brake jam	Proportional mechanism is damaged or worn	Replace
Damaged gear box	Hit by certain exterior force	Replace the damaged components
	Damaged gear train	Replace the damaged components
	Over load operation	Stop the winch operation and reduce a load
Motor runs extremely hot	Long period of operation	Allow to cool
	Damaged motor	Replace or repair motor
	Damaged or inoperative brake	Replace or repair brake



# Winch Assembly - REVO MKII 10,000LB Synthetic

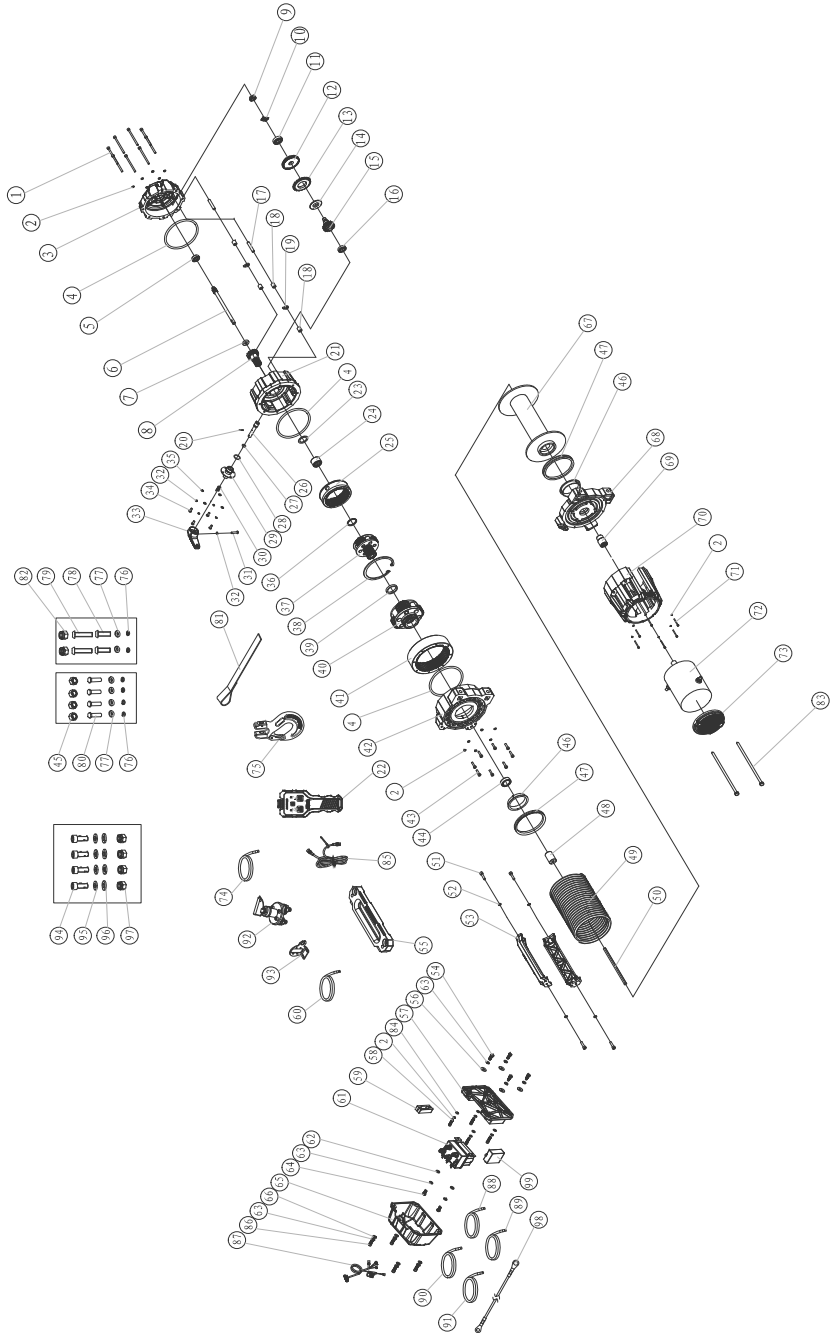

# REVO MKII 10,000LB Synthetic Model Parts List

No.	Description	Qty
1	Gearbox End Socket Head Cap Screw M5x80mm	8
2	Spring Washer M5	30
3	Gearbox End Cover	1
4	O Ring Seal	3
5	Gearbox Cover Ratchet Bearing	1
6	First Stage Gear Shaft	1
7	First Stage Anti-Wear Washer	1
8	Third Stage Sun Gear	1
9	Nut M12x1.25mm	1
10	Stop Washer M12	1
11	Ratchet Bearing	1
12	First Stage Ratchet Gear	1
13	Ratchet Gear with Friction Pad	1
14	Friction Brake Block	1
15	Second Stage Pinion Shaft	1
16	Second Stage Bearing	1
17	Pawl Pin	2
18	Pawl Spacer Bush	4
19	Pawl	2
20	Clutch Cam Cross Pin	1
21	Gearbox Housing Second Stage	1
22	Wireless Handheld Controller	1
23	Bearing Anti-Wear Washer	1
24	Needle Roller Bearing	1

Item No:	Description	Qty
25	Third Stage Rotating Ring Gear	1
26	Clutch Pin	1
27	Clutch Pin O Ring Small	1
28	Clutch Pin O Ring Large	1
29	Clutch Cam	1
30	Clutch Spring	1
31	Clutch Handle Socket Cap Screw M4x10mm	1
32	Clutch Spring Washer M4	5
33	Clutch Handle	1
34	Clutch Cam Button Head Cap Screws M4x12mm	4
35	Clutch Cam Flat Washer M4	4
36	Anti-Wear Washer	1
37	Third Stage Planetary Gear Assembly	1
38	Third Stage Retating Circlip	1
39	Third Stage Anti-Wear Washer	1
40	Fourth Stage Planetary Gear Assembly	1
41	Fourth Stage Gear Ring	1
42	Drum Support Gearbox Side	1
43	Fourth Stage Retaining Socket Head Cap Screw M5x20mm	8
44	Input Shaft Bearing	1
45	Winch Mounting Nut M10	4
46	Drum Bearing	2
47	Drum Support Seal	2
48	Shaft Coupler	1

Item No:	Description	Qty
49	Synthetic Rope 10mm x 28m	1
50	Motor Output Shaft	1
51	Tie Bar Socket Head Cap Screw M8x25mm	4
52	Tie Bar Spring Washer M8	4
53	Tie Bar	2
54	Hex Bolts M6x16mm	4
55	Aluminium Hawse Fairlead	1
56	Flat Washer M6x18mm OD	4
57	Control Box Base	1
58	Socket Head Cap Screw M5x20mm	8
59	Fuse Holder	1
60	Black 2AWG Earth Cable 1800mm	1
61	Contactora	1
62	Flat Washer M6	2
63	Spring Washer M6	10
64	Screw M6x14mm	2
65	Control Box Cover	1
66	Flat Washer M6	4
67	Drum Assembly	1
68	Drum Support Motor Side	1
69	Motor Coupling	1
70	10K Motor Cover	1
71	Motor Cover Socket Head Cap Screw M5x50mm	6
72	10K Motor Assembly	1
73	Motor End Cover	1
74	Red 2AWG Power Cable 500mm	1

Item No:	Description	Qty
75	Synthetic Rope 1/2"Hook	1
76	Spring Washer M10	6
77	Flat Washer M10	6
78	M10x40mm Button Head Cap Screw	2
79	M10x50mm Button Head Cap Screw	2
80	M10x35mm Hex Head Screw	4
81	Hand Strap	1
82	M10 Nyloc Nut	2
83	Motor Mounting Bolts M6x160mm	2
84	Flat Washer M5	4
85	Hand Controller Cable	1
86	Socket Head Cap Screw M6x16mm	4
87	Contactora Wiring Harness	1
88	Black 2AWG Contactora Cable (R) 600mm	1
89	Black 2AWG Contactora Cable (Y) 600mm	1
90	Black 2AWG Contactora Cable (B) 600mm	1
91	Red 2AWG Power Cable 1900mm	1
92	Isolation Switch	1
93	Isolation Switch Mounting Bracket	1
94	Socket Head Cap Screw M5x20mm	4
95	Flat Washer M5	4
96	Spring Washer M5	4
97	Nyloc Nut M5	4
98	Contactora Earth Wire	1
99	Wireless Receiver	1

# Winch Assembly - REVO MKII 10,000LB Wire

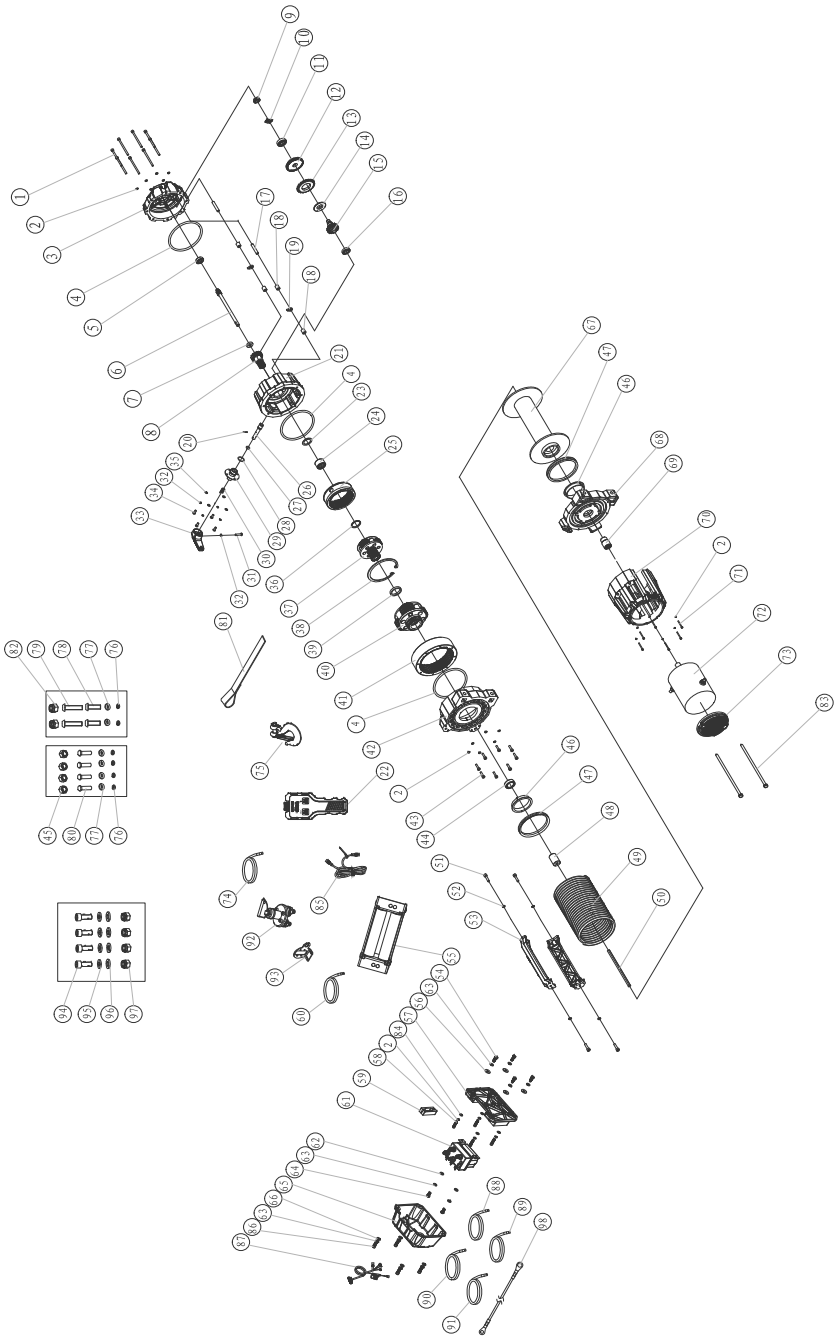

# REVO MKII 10,000LB Wire Model Parts List

Item No:	Description	Qty
1	Gearbox End Socket Head Cap Screw M5x80mm	8
2	Spring Washer M5	30
3	Gearbox End Cover	1
4	O Ring Seal	3
5	Gearbox Cover Ratchet Bearing	1
6	First Stage Gear Shaft	1
7	First Stage Anti-Wear Washer	1
8	Third Stage Sun Gear	1
9	Nut M12x1.25mm	1
10	Stop Washer M12	1
11	Ratchet Bearing	1
12	First Stage Ratchet Gear	1
13	Ratchet Gear with Friction Pad	1
14	Friction Brake Block	1
15	Second Stage Pinion Shaft	1
16	Second Stage Bearing	1
17	Pawl Pin	2
18	Pawl Spacer Bush	4
19	Pawl	2
20	Clutch Cam Cross Pin	1
21	Gearbox Housing Second Stage	1
22	Wired Handheld Controller	1
23	Bearing Anti-Wear Washer	1
24	Needle Roller Bearing	1

Item No:	Description	Qty
25	Third Stage Rotating Ring Gear	1
26	Clutch Pin	1
27	Clutch Pin O Ring Small	1
28	Clutch Pin O Ring Large	1
29	Clutch Cam	1
30	Clutch Spring	1
31	Clutch Handle Socket Cap Screw M4x10mm	1
32	Clutch Spring Washer M4	5
33	Clutch Handle	1
34	Clutch Cam Button Head Cap Screws M4x12mm	4
35	Clutch Cam Flat Washer M4	4
36	Anti-Wear Washer	1
37	Third Stage Planetary Gear Assembly	1
38	Third Stage Retating Circlip	1
39	Third Stage Anti-Wear Washer	1
40	Fourth Stage Planetary Gear Assembly	1
41	Fourth Stage Gear Ring	1
42	Drum Support Gearbox Side	1
43	Fourth Stage Retaining Socket Head Cap Screw M5x20mm	8
44	Input Shaft Bearing	1
45	Winch Mounting Nut M10	4
46	Drum Bearing	2
47	Drum Support Seal	2
48	Shaft Coupler	1

Item No:	Description	Qty
49	Wire Rope 9.2mm x 28m	1
50	Motor Output Shaft	1
51	Tie Bar Socket Head Cap Screw M8x25mm	4
52	Tie Bar Spring Washer M8	4
53	Tie Bar	2
54	Hex Bolts M6x16mm	4
55	Roller Fairlead	1
56	Flat Washer M6x18mm OD	4
57	Control Box Base	1
58	Socket Head Cap Screw M5x20mm	8
59	Fuse Holder	1
60	Black 2AWG Battery Cable 1800mm	1
61	Contactora	1
62	Flat Washer M6	2
63	Spring Washer M6	10
64	Screw M6x14mm	2
65	Control Box Cover	1
66	Flat Washer M6	4
67	Drum Assembly	1
68	Drum Support Motor Side	1
69	Motor Coupling	1
70	10K Motor Cover	1
71	Motor Cover Socket Head Cap Screw M5x50mm	6
72	10K Motor Assembly	1
73	Motor End Cover	1
74	Red 2AWG Cable 500mm	1

Item No:	Description	Qty
75	Wire Rope 3/8"Hook	1
76	Spring Washer M10	6
77	Flat Washer M10	6
78	M10x40mm Button Head Cap Screw	2
79	M10x45mm Button Head Cap Screw	2
80	M10x35mm Hex Head Screw	4
81	Hand Strap	1
82	M10 Nyloc Nut	2
83	Motor Mounting Bolts M6x160mm	2
84	Flat Washer M5	4
85	Hand Controller Cable	1
86	Socket Head Cap Screw M6x16mm	4
87	Contactora Wiring Harness	1
88	Black 2AWG Contactora Cable (R) 600mm	1
89	Black 2AWG Contactora Cable (Y) 600mm	1
90	Black 2AWG Contactora Cable (B) 600mm	1
91	Red 2AWG Battery Cable 1900mm	1
92	Isolation Switch	1
93	Isolation Switch Mounting Bracket	1
94	Socket Head Cap Screw M5x20mm	4
95	Flat Washer M5	4
96	Spring Washer M5	4
97	Nyloc Nut M5	4
98	Contactora Earth Wire	1



# REVO MKII 12,000LB Synthetic Model Parts List

No.	Description	Qty
1	Gearbox End Socket Head Cap Screw M5x80mm	8
2	Spring Washer M5	30
3	Gearbox End Cover	1
4	O Ring Seal	3
5	Gearbox Cover Ratchet Bearing	1
6	First Stage Gear Shaft	1
7	First Stage Anti-Wear Washer	1
8	Third Stage Sun Gear	1
9	Nut M12x1.25mm	1
10	Stop Washer M12	1
11	Ratchet Bearing	1
12	First Stage Ratchet Gear	1
13	Ratchet Gear with Friction Pad	1
14	Friction Brake Block	1
15	Second Stage Pinion Shaft	1
16	Second Stage Bearing	1
17	Pawl Pin	2
18	Pawl Spacer Bush	4
19	Pawl	2
20	Clutch Cam Cross Pin	1
21	Gearbox Housing Second Stage	1
22	Wireless Handheld Controller	1
23	Bearing Anti-Wear Washer	1
24	Needle Roller Bearing	1

Item No:	Description	Qty
25	Third Stage Rotating Ring Gear	1
26	Clutch Pin	1
27	Clutch Pin O Ring Small	1
28	Clutch Pin O Ring Large	1
29	Clutch Cam	1
30	Clutch Spring	1
31	Clutch Handle Socket Cap Screw M4x10mm	1
32	Clutch Spring Washer M4	5
33	Clutch Handle	1
34	Clutch Cam Button Head Cap Screws M4x12mm	4
35	Clutch Cam Flat Washer M4	4
36	Anti-Wear Washer	1
37	Third Stage Planetary Gear Assembly	1
38	Third Stage Retating Circlip	1
39	Third Stage Anti-Wear Washer	1
40	Fourth Stage Planetary Gear Assembly	1
41	Fourth Stage Gear Ring	1
42	Drum Support Gearbox Side	1
43	Fourth Stage Retaining Socket Head Cap Screw M5x20mm	8
44	Input Shaft Bearing	1
45	Winch Mounting Nut M10	4
46	Drum Bearing	2
47	Drum Support Seal	2
48	Shaft Coupler	1



Item No:	Description	Qty
49	Synthetic Rope 11mm x 24m	1
50	Motor Output Shaft	1
51	Tie Bar Socket Head Cap Screw M8x25mm	4
52	Tie Bar Spring Washer M8	4
53	Tie Bar	2
54	Hex Bolts M6x16mm	4
55	Aluminium Hawse Fairlead	1
56	Flat Washer M6x18mm OD	4
57	Control Box Base	1
58	Socket Head Cap Screw M5x20mm	8
59	Fuse Holder	1
60	Black 2AWG Battery Cable 1800mm	1
61	Contactora	1
62	Flat Washer M6	2
63	Spring Washer M6	10
64	Screw M6x14mm	2
65	Control Box Cover	1
66	Flat Washer M6	4
67	Drum Assembly	1
68	Drum Support Motor Side	1
69	Motor Coupling	1
70	12K Motor Cover	1
71	Motor Cover Socket Head Cap Screw M5x50mm	6
72	12K Motor Assembly	1
73	Motor End Cover	1
74	Red 2AWG Cable 500mm	1

Item No:	Description	Qty
75	Synthetic Rope 1/2"Hook	1
76	Spring Washer M10	6
77	Flat Washer M10	6
78	M10x40mm Button Head Cap Screw	2
79	M10x50mm Button Head Cap Screw	2
80	M10x35mm Hex Head Screw	4
81	Hand Strap	1
82	M10 Nyloc Nut	2
83	Motor Mounting Bolts M6x160mm	2
84	Flat Washer M5	4
85	Hand Controller Cable	1
86	Socket Head Cap Screw M6x16mm	4
87	Contactora Wiring Harness	1
88	Black 2AWG Contactora Cable (R) 600mm	1
89	Black 2AWG Contactora Cable (Y) 600mm	1
90	Black 2AWG Contactora Cable (B) 600mm	1
91	Red 2AWG Battery Cable 1900mm	1
92	Isolation Switch	1
93	Isolation Switch Mounting Bracket	1
94	Socket Head Cap Screw M5x20mm	4
95	Flat Washer M5	4
96	Spring Washer M5	4
97	Nyloc Nut M5	4
98	Contactora Earth Wire	1
99	Wireless Receiver	1

# Winch Assembly - REVO MKII 12,000LB Wire

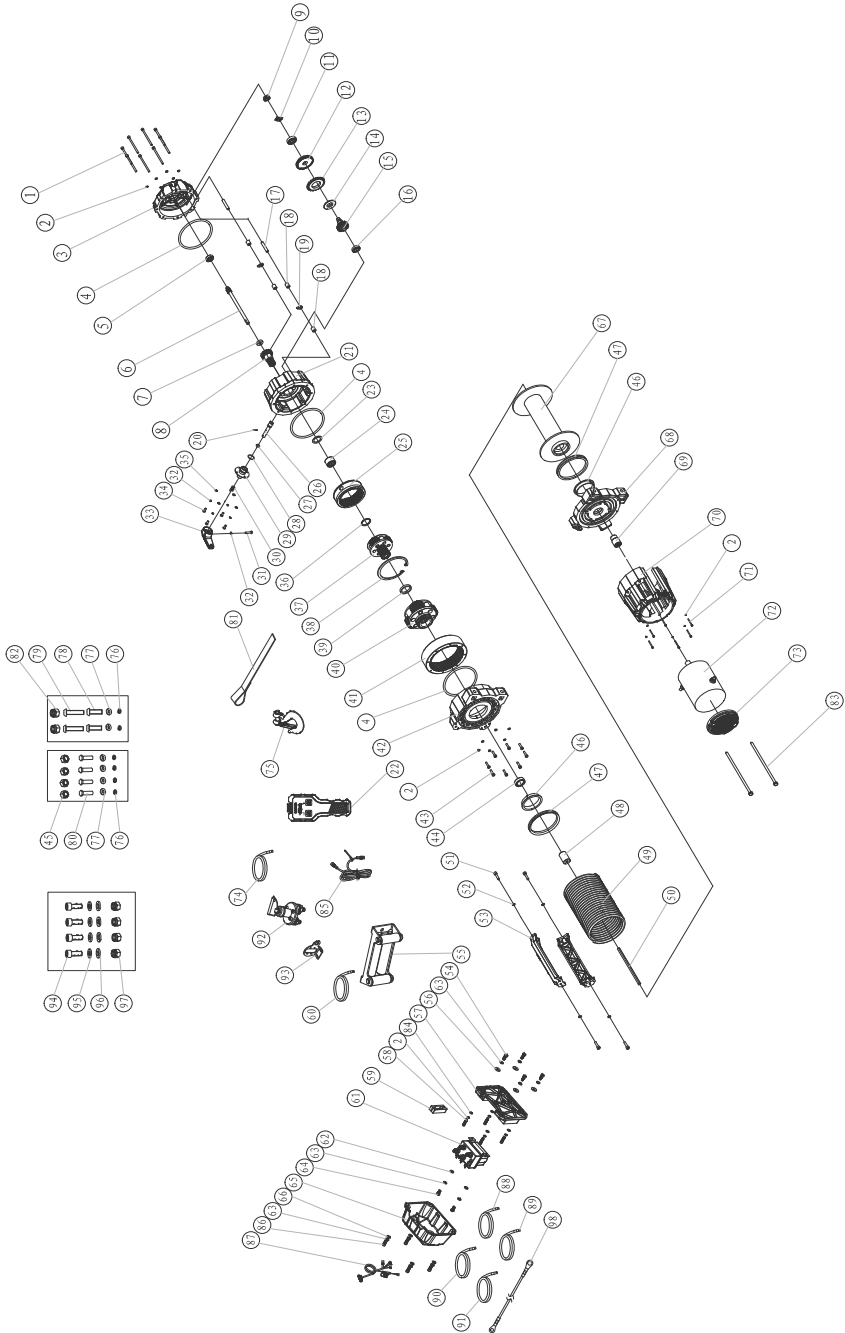

# REVO MKII 12,000LB Wire Model Parts List

Item No:	Description	Qty
1	Gearbox End Socket Head Cap Screw M5x80mm	8
2	Spring Washer M5	30
3	Gearbox End Cover	1
4	O Ring Seal	3
5	Gearbox Cover Ratchet Bearing	1
6	First Stage Gear Shaft	1
7	First Stage Anti-Wear Washer	1
8	Third Stage Sun Gear	1
9	Nut M12x1.25mm	1
10	Stop Washer M12	1
11	Ratchet Bearing	1
12	First Stage Ratchet Gear	1
13	Ratchet Gear with Friction Pad	1
14	Friction Brake Block	1
15	Second Stage Pinion Shaft	1
16	Second Stage Bearing	1
17	Pawl Pin	2
18	Pawl Spacer Bush	4
19	Pawl	2
20	Clutch Cam Cross Pin	1
21	Gearbox Housing Second Stage	1
22	Wired Handheld Controller	1
23	Bearing Anti-Wear Washer	1
24	Needle Roller Bearing	1

Item No:	Description	Qty
25	Third Stage Rotating Ring Gear	1
26	Clutch Pin	1
27	Clutch Pin O Ring Small	1
28	Clutch Pin O Ring Large	1
29	Clutch Cam	1
30	Clutch Spring	1
31	Clutch Handle Socket Cap Screw M4x10mm	1
32	Clutch Spring Washer M4	5
33	Clutch Handle	1
34	Clutch Cam Button Head Cap Screws M4x12mm	4
35	Clutch Cam Flat Washer M4	4
36	Anti-Wear Washer	1
37	Third Stage Planetary Gear Assembly	1
38	Third Stage Retating Circlip	1
39	Third Stage Anti-Wear Washer	1
40	Fourth Stage Planetary Gear Assembly	1
41	Fourth Stage Gear Ring	1
42	Drum Support Gearbox Side	1
43	Fourth Stage Retaining Socket Head Cap Screw M5x20mm	8
44	Input Shaft Bearing	1
45	Winch Mounting Nut M10	4
46	Drum Bearing	2
47	Drum Support Seal	2
48	Shaft Coupler	1

Item No:	Description	Qty
49	Wire Rope 10.3mm x 25m	1
50	Motor Output Shaft	1
51	Tie Bar Socket Head Cap Screw M8x25mm	4
52	Tie Bar Spring Washer M8	4
53	Tie Bar	2
54	Hex Bolts M6x16mm	4
55	Roller Fairlead	1
56	Flat Washer M6x18mm OD	4
57	Control Box Base	1
58	Socket Head Cap Screw M5x20mm	8
59	Fuse Holder	1
60	Black 2AWG Battery Cable 1800mm	1
61	Contactora	1
62	Flat Washer M6	2
63	Spring Washer M6	10
64	Screw M6x14mm	2
65	Control Box Cover	1
66	Flat Washer M6	4
67	Drum Assembly	1
68	Drum Support Motor Side	1
69	Motor Coupling	1
70	12K Motor Cover	1
71	Motor Cover Socket Head Cap Screw M5x50mm	6
72	12K Motor Assembly	1
73	Motor End Cover	1

Item No:	Description	Qty
74	Red 2AWG Cable 500mm	1
75	Wire Rope 1/2"Hook	1
76	Spring Washer M10	6
77	Flat Washer M10	6
78	M10x40mm Button Head Cap Screw	2
79	M10x45mm Button Head Cap Screw	2
80	M10x35mm Hex Head Screw	4
81	Hand Strap	1
82	M10 Nyloc Nut	2
83	Motor Mounting Bolts M6x160mm	2
84	Flat Washer M5	4
85	Hand Controller Cable	1
86	Socket Head Cap Screw M6x16mm	4
87	Contactora Wiring Harness	1
88	Black 2AWG Contactora Cable (R) 600mm	1
89	Black 2AWG Contactora Cable (Y) 600mm	1
90	Black 2AWG Contactora Cable (B) 600mm	1
91	Red 2AWG Battery Cable 1900mm	1
92	Isolation Switch	1
93	Isolation Switch Mounting Bracket	1
94	Socket Head Cap Screw M5x20mm	4
95	Flat Washer M5	4
96	Spring Washer M5	4
97	Nyloc Nut M5	4
98	Contactora Earth Wire	1

# BUSHRANGER PRODUCTS - WARRANTY POLICY

## 1. Our Warranty

We warrant to you that the Bushranger product is free from defects in workmanship and materials for the warranty period.

## 2. Fitting and use

Please ensure you:

- a. Fit the Bushranger product in accordance with the product information and all relevant vehicle safety and compliance laws
- b. Use the Bushranger product for the purpose for which it was originally designed and in accordance with the product information and all relevant vehicle safety and compliance laws

## 3. Exclusions

Our warranty doesn't cover:

- a. Normal wear and tear
- b. Wear from the use of synthetic or wire ropes.
- c. Surface finish from use
- d. Fitting the Bushranger product other than in accordance with the product information and any relevant vehicle safety and compliance laws, including incorrect fitting
- e. Using the Bushranger product other than for the purpose for which it was originally designed or other than in accordance with the product information and any relevant vehicle safety and compliance laws, including unusual, improper or negligent use or misuse or overloading
- f. Misuse or neglect of the Bushranger product, including improper repair or maintenance or failing to repair or maintain
- g. Alteration, abuse, acts of nature, terrorism, vandalism, collision, road hazards or adverse conditions
- h. Removal or re-installation of the winch

## 4. Making a claim

Please immediately contact us as soon as you become aware of a possible defect in the Bushranger product. We'll arrange for you to either attend a Bushranger outlet (at your cost) for a Bushranger representative to inspect the Bushranger product (as fitted to your vehicle) or for you to return the Bushranger product to us. We'll also request you to provide the purchase receipt and complete a warranty claim form. In order to ensure our warranty is not voided, please keep the purchase receipt as proof of purchase and don't remove the fitted Bushranger product from your vehicle before contacting us. Note: Non-transferable warranty. The original purchaser can only claim warranty. If your claim's in order, we'll notify you and (at our sole discretion) either repair or replace the defective workmanship or materials (at our cost) or refund to you the purchase price you paid for the defective Bushranger product. If further information or investigation is required or if the claim does not meet the requirements under our warranty, we'll let you know.

### 1. Australian Consumer Law

The Bushranger product comes with guarantees that can't be excluded under the Australian Consumer Law. You're entitled to a replacement or refund if there's a major failure and compensation for any other reasonably foreseeable loss or damage. You're also entitled to have the Bushranger product repaired or replaced if it fails to be of acceptable quality and the failure doesn't amount to a major failure.

### 2. Other consumer rights

The benefits to you under our warranty are in addition to any other rights and remedies you are entitled to under relevant consumer laws. Our warranty replaces any other warranty given by Bushranger or its supplier in respect of the Bushranger product.

### 3. Terms

The following terms have the following meanings:

Term	Meaning
Product information	Information about the Bushranger product which may be contained in any of the documentation provided with the Bushranger product, including safety instructions, installation instructions, operating instructions, owner's manual, service manual, labels and packaging.
Purchase date	The date you purchased the Bushranger product from a Bushranger outlet, as specified in the purchase receipt.
Bushranger outlet	An outlet authorised by Bushranger to sell Bushranger products.
Bushranger products	Products or components which Bushranger manufactures or sells through Bushranger outlets.
Warranty period	Commences on and from the purchase date and ends as follows: <b>Limited Lifetime Warranty (7 Year Warranty on Electrical components).</b>
We/Us	Kingsley Enterprises Pty Ltd (ABN 23 001 592 749) E: sales@bushranger.com.au A: 6A Brooks Road, Ingleburn NSW 2565 P: 1800 654 767 W: www.bushranger.com.au
You	The purchaser of the Bushranger product from a Bushranger outlet.



[www.bushranger.com.au/winch](http://www.bushranger.com.au/winch)

**BUSHRANGER**  
4x4 GEAR

**Kingsley Enterprises PTY. LTD.**

Free Call | 1800 654 767 (Australia Only)

International | +61 2 8700 0400

Email | [sales@bushranger.com.au](mailto:sales@bushranger.com.au)

Address | 6A Brooks Road, Ingleburn NSW 2565

0284-230