

**BUSHRANGER**  
**4x4 GEAR**

# WHEELIE BIN

SPARE WHEEL BAG

OWNERS MANUAL

CBW010

**WHEELIE BIN**

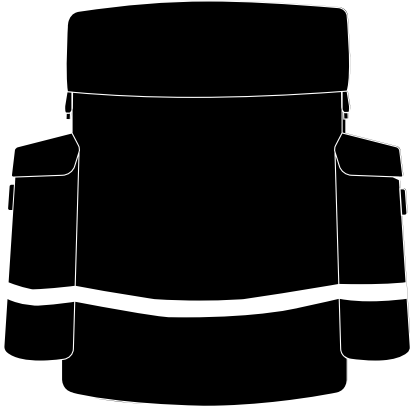

**INCLUDES:**

1x Spare Wheel Bag

1x Owners Manual

## CARE AND FITTING GUIDELINES

The Bushranger Wheelie Bin is normally strapped to vehicles with a rear mounted spare wheel. Adjustable pull-straps allow the “Wheelie Bin” to suit most vehicles.

*Note: For clarity purposes, some images included with these instructions are shown with the wheel removed from the vehicle.*

### Care & Maintenance

- Do not expose Wheelie Bin to any petroleum-based, acids or alkaline products.
- Clean Wheelie Bin regularly with a non-abrasive sponge or similar in warm water and pH neutral car washing liquids only. Allow to dry in the shade to preserve shine and promote longevity.
- Always ensure Wheelie Bin is dry prior to being stored.

## BEFORE FIRST USE

- Check local laws and regulations before attaching any external components onto your vehicle.
- Confirm the spare wheel is suitable for mounting of this product (fully laden) with the vehicle manufacturer and the manufacturer of any aftermarket wheel carrier installed before using this product.
- Always consider the additional stresses from the environment and application in determining if the product can be used.



## WARNING

- Avoid carrying sharp objects (including broken glass).
- Avoid carrying harmful chemicals/oils.
- Never carry hot materials.
- It is recommended not to exceed 10 kilograms of weight within the wheelie bin and to reduce this amount when traveling on rough terrain.

### Vehicle

- Prior to strapping the “Wheelie Bin” to a rear mounted spare wheel, check that all wheel nuts are tightened to the correct torque.
- Do not reduce visibility of the licence plate in anyway.

### Product

- Always check lid is completely buckled closed before driving.
- Regularly check buckles and straps are secure when driving.

### Safety & Inspection

Prior to using the Wheelie Bin or any of its components inspect for damage including:

- Evidence of heavy impacts.
- Cuts and abrasions.
- Badly worn
- Seam damage
- Deformation

**FITTING GUIDE****Step 1**

Position the Wheelie Bin over the wheel and the horizontal bracing strap should be snug across the top edge of the tyre.

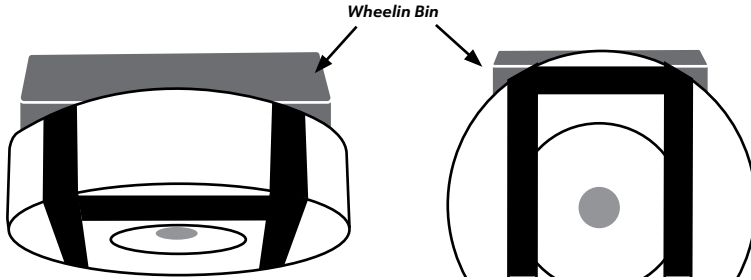

*View from behind the wheel*

**Step 2**

Arrange the harness (webbing straps) so that the straps go behind the wheel. There are several methods in which the "Wheelie Bin" may be strapped to a vehicles spare wheel dependent upon the users' preference.

**Method 1: Vertical**

The harness straps are in a vertical position.

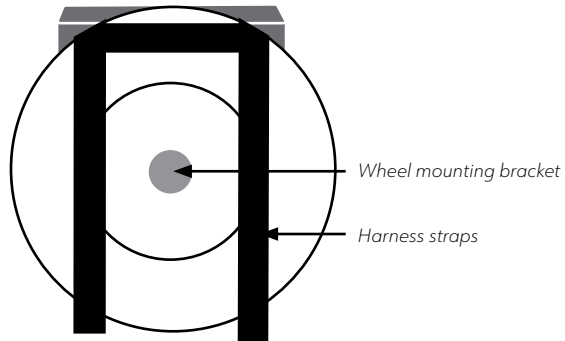

*View from behind the wheel*

**Step 2 Continued...****Method 2: Criss Cross**

Cross the harness strap past each other underneath the wheel mounting bracket.

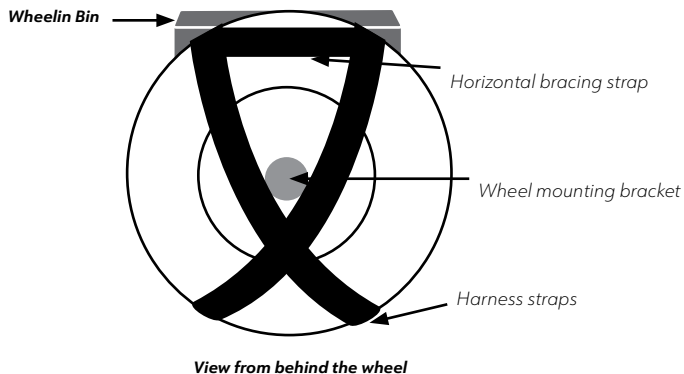

Check that the wheel mounting bracket will not damage the straps and the straps will not damage the vehicle.

**Step 3**

Clip the buckles together on the underside of the wheel & tighten the pull straps, ensuring there are no twists in the straps.

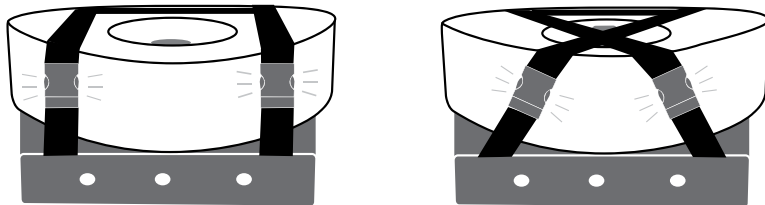
**Step 4**

Check to ensure that harness and bag is snug on the wheel. checking the clips are firmly engaged and secure. Excess straps can be loosley tied together to stop flapping or dragging.

## **Bushranger Products - Warranty Policy**

### **1. Our Warranty**

We warrant to you that the Bushranger product is free from defects in workmanship and materials for the warranty period.

### **2. Fitting and use**

Please ensure you:

- a. fit the Bushranger product in accordance with the product information and all relevant vehicle safety and compliance laws
- b. use the Bushranger product for the purpose for which it was originally designed and in accordance with the product information and all relevant vehicle safety and compliance laws

### **3. Exclusions**

Our warranty doesn't cover:

- a. normal wear and tear
- b. fitting the Bushranger product other than in accordance with the product information and any relevant vehicle safety and compliance laws, including incorrect fitting
- c. using the Bushranger product other than for the purpose for which it was originally designed or other than in accordance with the product information and any relevant vehicle safety and compliance laws, including unusual, improper or negligent use or misuse or overloading
- d. misuse or neglect of the Bushranger product, including improper repair or maintenance or failing to repair or maintain
- e. alteration, abuse, acts of nature, terrorism, vandalism, collision, road hazards or adverse conditions

### **4. Making a claim**

Please immediately contact us as soon as you become aware of a possible defect in the Bushranger product. We'll arrange for you to either attend a Bushranger outlet (at your cost) for a Bushranger representative to inspect the Bushranger product (as fitted to your vehicle) or for you to return the Bushranger product to us. We'll also request you to provide the purchase receipt and complete a warranty claim form. In order to ensure our warranty is not voided, please keep the purchase receipt as proof of purchase and don't remove the fitted Bushranger product from your vehicle before contacting us. If your claim's in order, we'll notify you and (at our sole discretion) either repair or replace the defective workmanship or materials (at our cost) or refund to you the purchase price you paid for the defective Bushranger product. If further information or investigation is required or if the claim does not meet the requirements under our warranty, we'll let you know.

### **5. Australian Consumer Law**

The Bushranger product comes with guarantees that can't be excluded under the Australian Customer Law. You're entitled to a replacement or refund if there's a major failure and compensation for any other reasonably foreseeable loss or damage. You're also entitled to have the Bushranger product repaired or replaced if it fails to be of acceptable quality and the failure doesn't amount to a major failure.

### **6. Other consumer rights**

The benefits to you under our warranty are in addition to any other rights and remedies you are entitled to under relevant consumer laws. Our warranty replaces any other warranty given by Bushranger or it's supplier in respect of the Bushranger product.

## 7. Terms

The following terms have the following meanings:

Term	Meaning
Product information	information about the Bushranger product which may be contained in any of the documentation provided with the Bushranger product, including safety instructions, installation instructions, operating instructions, owner's manual, service manual, labels and packaging
Purchase date	the date you purchased the Bushranger product from a Bushranger outlet, as specified in the purchase receipt
Bushranger outlet	an outlet authorised by Bushranger to sell Bushranger products
Bushranger products	products or components which Bushranger manufactures or sells through Bushranger outlets
Warranty period	commences on and from the purchase date and ends as follows: <b>Wheelie Bin - 5 years</b>
We/Us	Kingsley Enterprises Pty Ltd (ABN 23 001 592 749) E: sales@bushranger.com.au A: 6A Brooks Road, Ingleburn NSW 2565 P: 1800 654 767 W: www.bushranger.com.au
You	the purchaser of the Bushranger product from a Bushranger outlet

**BUSHRANGER**  
**4x4 GEAR**

[www.bushranger.com.au](http://www.bushranger.com.au)